



Envirosense SF[®]

HIGH-EFFICIENCY RESIDENTIAL GAS WATER HEATERS

Flexible, Powerful & Highly Efficient Gas Water Heaters.

Commercial-grade hot water delivery is now more attainable than ever. The Envirosense SF[®] provides flexible, powerful and highly efficient performance to the everyday home. The fully condensing Envirosense SF[®] design is so advanced, it can deliver continuous hot water at a constant flow of over 2.5 gallons per minute.*

ENERGY STAR[®] QUALIFIED

CONDENSING DESIGN

- High efficiency operation with up to 0.90 Uniform Energy Factor to save money on operating costs

SIDE FIRED GAS BURNER

- Unique side fire design allows for optimal burner placement

HELICAL INTERNAL HEAT EXCHANGER

- Spiral heat exchanger keeps hot combustion gases in the tank longer to lengthen the heat transfer cycle
- Positioned in the center of the tank for more even heat distribution
- Spiral design reduces the effect of lime scale and sediment on the heat exchanger to maintain high-efficiency operation over time

POWER VENT AND POWER DIRECT VENT WITH A SINGLE DESIGN

- Combined vertical and horizontal runs terminating through an outside wall. Vents using PVC, CPVC, or polypropylene pipe.
- 2" pipe vents up to 60 equivalent feet
- 3" pipe vents up to 150 equivalent feet

ADVANCED ELECTRONIC CONTROL

- Precise temperature control
- Built-in diagnostics and operational information

SIDE-MOUNTED HOT AND COLD RECIRCULATING TAPS

- Allows Envirosense SF to be installed as part of combination space heating/water heating applications

HEAVY-DUTY ANODIC PROTECTION

- Comes standard with dual sacrificial anodes to protect the tank
- Optional Powered Anode available for enhanced tank protection in all water conditions

GLASS TANK LINING

- Provides superior corrosion resistance compared to industry standard glass lining.

CSA CERTIFIED AND ASME RATED T&P RELIEF VALVE

MAXIMUM HYDROSTATIC WORKING PRESSURE: 150 PSI

AVAILABLE IN NATURAL GAS

CODE COMPLIANCE

- Meets NRCan and provincial thermal efficiency and standby loss requirements.

DESIGN-CERTIFIED BY CSA

- Certified at 300 psi test pressure and 150 psi working pressure. Listed according to ANSI Z21.10.1 - CSA 4.1 standards governing storage tank-type water heaters.

6-YEAR LIMITED TANK AND PARTS WARRANTY

- For complete information, consult written warranty or go to hotwater.com

*Continuous hot water based on 65,000 BTU unit, 2.8 GPM continuous flow with a 65°F inlet water temperature, 110°F outlet temperature, and installed per the manufacturer's instructions.



MODEL SHOWN ENV-40





Envirosense SF[®]

HIGH-EFFICIENCY RESIDENTIAL GAS WATER HEATERS

MODEL NUMBER	NOMINAL CAPACITY USG (L)	RATED STORAGE VOLUME USG (L)	FIRST HOUR RATING USG (L)	UEF	THERMAL EFFICIENCY	RECOVERY @ 90° RISE GPH (LPH)	BTU INPUT PER HOUR	APPROX. SHIPPING WEIGHT LB (KG)
ENV-40N	40 (151)	39 (147)	86 (325)	0.90	93%	62 (234)	50,000	216 (98.2)
ENV-50N	50 (189)	48 (181)	118 (446)	0.90	93%	81 (306)	65,000	246 (111.8)

Available in natural gas only.

Top Inlet and outlet connections: 3/4" male NPT. Circulation loop connections: 3/4" female NPT

Models certified for sea level to 10,100 ft. elevation.

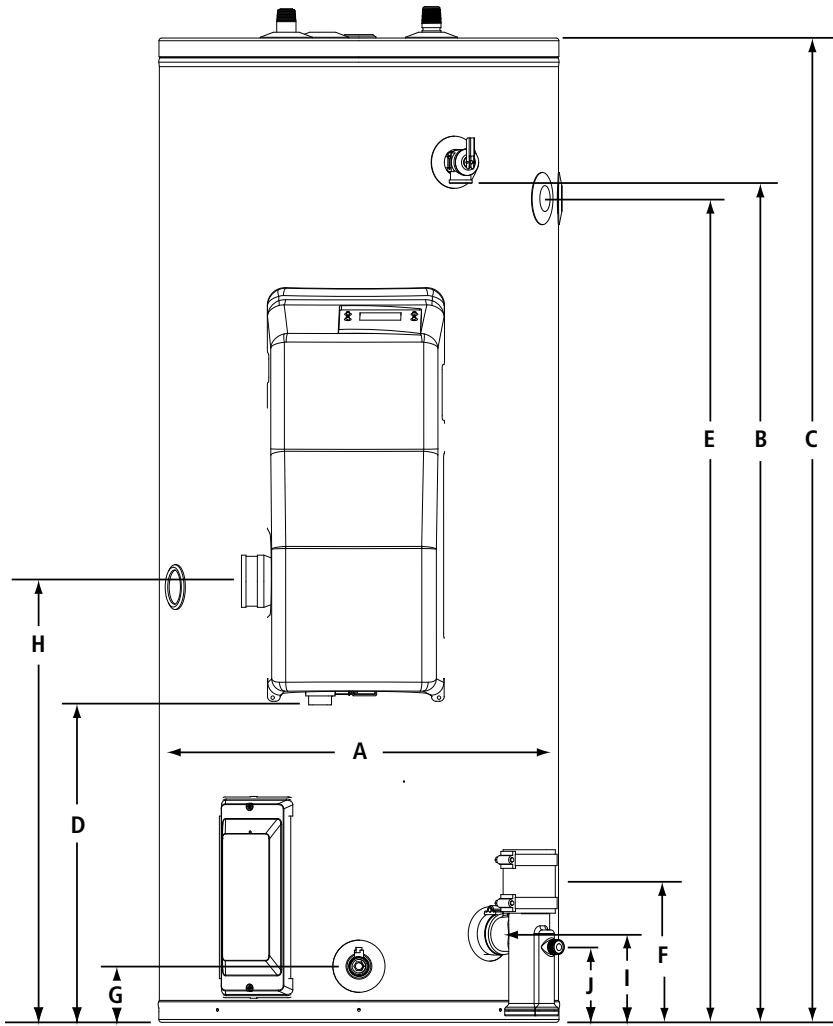

	DESCRIPTION	DIMENSIONS IN (CM)	
		40 GAL	50 GAL
A	DIAMETER	22 (56)	22 (56)
B	HEIGHT TO T&P	38-3/8 (97)	47-3/8 (120)
C	HEIGHT TO TOP	44-7/8 (114)	54-1/4 (138)
D	HEIGHT TO GAS CONNECTION	16-1/2 (42)	17-1/2 (44)
E	HEIGHT TO UPPER SIDE CONNECT	36-3/8 (92)	45-3/8 (115)
F	HEIGHT TO LOWER SIDE CONNECT	8-5/8 (22)	7-7/8 (20)
G	HEIGHT TO DRAIN VALVE	3-7/8 (10)	3 (8)
H	HEIGHT TO AIR INTAKE	22-1/8 (56)	24-1/4 (62)
I	HEIGHT TO EXHAUST	5-3/8 (14)	4-7/8 (12)
J	HEIGHT TO CONDENSATE CONNECTION	5-1/2 (14)	4 (10)
K	OVERALL DEPTH	28-1/2 (72)	28-1/2 (72)
L	WATER CONNECTIONS	8 (20)	8 (20)

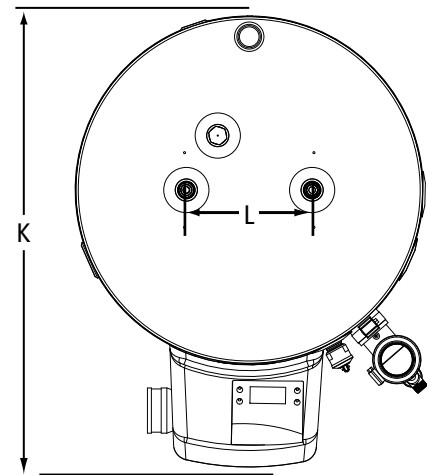

OPTIONAL ACCESSORIES

PART NUMBER	DESCRIPTION
100112869	2" concentric termination kit
100111100	3" concentric termination kit
100187903	2" low-profile termination kit
100187887	3" low-profile termination kit
100112159	Condensate neutralizer kit
100305721	Powered anode kit