



Envirosense[®] SF

HIGH-EFFICIENCY RESIDENTIAL GAS WATER HEATERS

Flexible, Powerful & Highly Efficient Gas Water Heaters.

Commercial-grade hot water delivery is now more attainable than ever. The Envirosense SF provides flexible, powerful and highly efficient performance to the everyday home. The fully condensing Envirosense SF design is so advanced, it can deliver continuous hot water at a constant flow of over 2.5 gallons per minute.*

ENERGY STAR[®] QUALIFIED

CONDENSING DESIGN

- High efficiency operation with up to 0.90 Uniform Energy Factor to save money on operating costs

SIDE FIRED GAS BURNER

- Unique side fire design allows for optimal burner placement

HELICAL INTERNAL HEAT EXCHANGER

- Spiral heat exchanger keeps hot combustion gases in the tank longer to lengthen the heat transfer cycle
- Positioned in the center of the tank for more even heat distribution
- Spiral design reduces lime scale formation on the heat exchanger to maintain high efficiency operation over time

POWER VENT AND POWER DIRECT VENT WITH A SINGLE DESIGN

- Combined vertical and horizontal runs terminating through an outside wall. Vents using PVC, CPVC, or polypropylene pipe.
- 2" pipe vents up to 60 equivalent feet
- 3" pipe vents up to 150 equivalent feet

ADVANCED ELECTRONIC CONTROL

- Precise temperature control
- Built-in diagnostics and operational information

SIDE-MOUNTED HOT AND COLD RECIRCULATING TAPS

- Allows Envirosense SF to be installed as part of combination space heating/water heating applications

HEAVY-DUTY ANODIC PROTECTION

- Comes standard with dual sacrificial anodes to protect the tank
- Optional Powered Anode available for enhanced tank protection in all water conditions

GLASS TANK LINING

- Provides superior corrosion resistance compared to industry standard glass lining.

CSA CERTIFIED AND ASME RATED T&P RELIEF VALVE

MAXIMUM HYDROSTATIC WORKING PRESSURE: 150 PSI

AVAILABLE IN NATURAL GAS

CODE COMPLIANCE

- Meets NRCan and provincial thermal efficiency and standby loss requirements.

DESIGN-CERTIFIED BY CSA

- Certified at 300 psi test pressure and 150 psi working pressure. Listed according to ANSI Z21.10.1 - CSA 4.1 standards governing storage tank-type water heaters.

6-YEAR LIMITED TANK AND PARTS WARRANTY

- For complete information, consult written warranty or go to hotwater.com

*Continuous hot water based on 65,000 BTU unit, 2.8 GPM continuous flow with a 65°F inlet water temperature, 110°F outlet temperature, and installed per the manufacturer's instructions.



MODEL SHOWN ENV-40





Envirosense[®] SF

HIGH-EFFICIENCY RESIDENTIAL GAS WATER HEATERS

MODEL NUMBER	NOMINAL CAPACITY USG (L)	RATED STORAGE VOLUME USG (L)	FIRST HOUR RATING USG (L)	UEF	THERMAL EFFICIENCY	RECOVERY @ 90° RISE GPH (LPH)	BTU INPUT PER HOUR	APPROX. SHIPPING WEIGHT LB (KG)
ENV-40N	40 (151)	39 (147)	86 (325)	0.90	93%	62 (234)	50,000	216 (98.2)
ENV-50N	50 (189)	48 (181)	118 (446)	0.90	93%	81 (306)	65,000	246 (111.8)

Available in natural gas only.

Top Inlet and outlet connections: 3/4" male NPT. Circulation loop connections: 3/4" female NPT

Models certified for sea level to 10,100 ft. elevation.

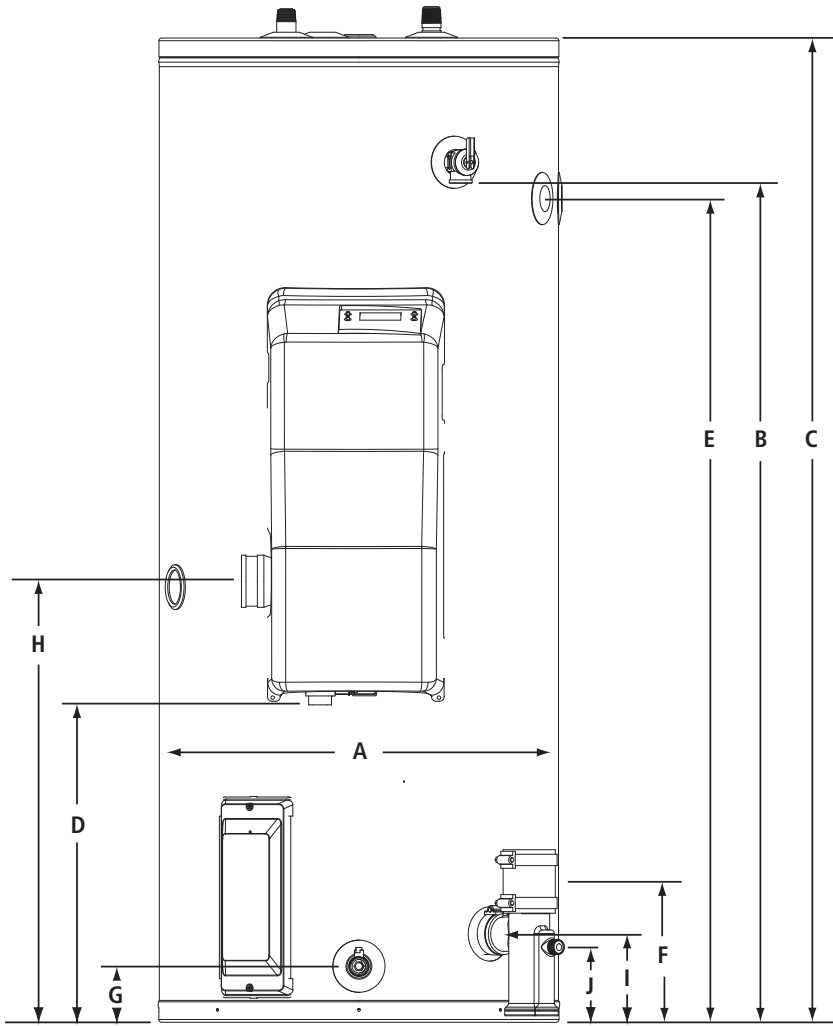

	DESCRIPTION	DIMENSIONS IN (CM)	
		40 GAL	50 GAL
A	DIAMETER	22 (56)	22 (56)
B	HEIGHT TO T&P	38-3/8 (97)	47-3/8 (120)
C	HEIGHT TO TOP	44-7/8 (114)	54-1/4 (138)
D	HEIGHT TO GAS CONNECTION	16-1/2 (42)	17-1/2 (44)
E	HEIGHT TO UPPER SIDE CONNECT	36-3/8 (92)	45-3/8 (115)
F	HEIGHT TO LOWER SIDE CONNECT	8-5/8 (22)	7-7/8 (20)
G	HEIGHT TO DRAIN VALVE	3-7/8 (10)	3 (8)
H	HEIGHT TO AIR INTAKE	22-1/8 (56)	24-1/4 (62)
I	HEIGHT TO EXHAUST	5-3/8 (14)	4-7/8 (12)
J	HEIGHT TO CONDENSATE CONNECTION	5-1/2 (14)	4 (10)
K	OVERALL DEPTH	28-1/2 (72)	28-1/2 (72)
L	WATER CONNECTIONS	8 (20)	8 (20)

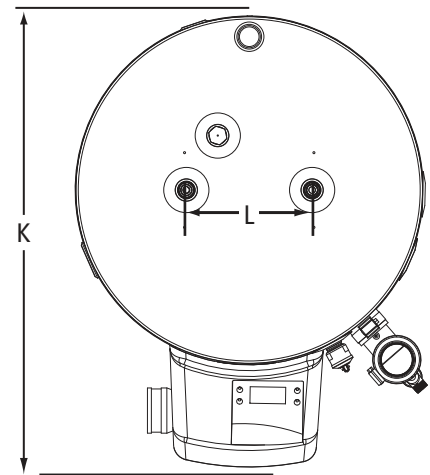

OPTIONAL ACCESSORIES

PART NUMBER	DESCRIPTION
100112869	2" concentric termination kit
100111100	3" concentric termination kit
100187903	2" low-profile termination kit
100187887	3" low-profile termination kit
100112159	Condensate neutralizer kit
100305721	Powered anode kit