



EnviroFX

Residential Gas Hybrid Water Heater

Introducing the EnviroFX - the latest in cutting edge technology from GSW Water Heating that combines the best attributes of conventional and tankless technology.

WATER HEATER FEATURES

Energy Efficiency

- Patented circulation system delivers 90% thermal efficiency, ensuring maximum heat transfer, saving money on operating costs compared to a standard 78% efficient conventional or 84% tankless gas water heaters.
- Condensing design includes condensate drain trap

Hybrid Technology

- Innovative technology that surpasses existing conventional and tankless designs
- Patented water flow circulation system provides the performance of a tankless unit with extremely quick recovery
- First hour delivery of 189 gallons of hot water
- Smaller than a conventional 50-gallon gas water heater, but with twice the hot water delivery
- Whole-home solution regardless of geography

Improved Hot Water Delivery

- Continuous hot water shower after shower when properly sized for your home
- No minimum flow rate for ignition
- No cold water sandwich
- Delivers hot water faster than tankless
- Internal storage easily handles peak demand

Sophisticated Electronics

- User-friendly integrated temperature controller with LED numeric display allows for precise temperature settings
- Multiple Lifestyle Modes - Energy Saver, Vacation and Boost modes allow for simple one-touch customization based on specific hot water needs
- Safety lock feature deters unwanted access
- Error code display for easy troubleshooting

Lower Installation Costs

- Utilizes 1/2" gas line standard in most homes today
- Extremely low exhaust temperature enables ULC S636 approved PVC or CPVC venting for easier, more economical installations
- Hot and cold water connections similar to conventional tank-style models

Power Vent Design

- Uses inexpensive ULC S636 PVC or CPVC pipe for venting
- Can be vented vertically thru-the-roof or horizontally thru-the-wall
- 2" pipe vents up to 50 equivalent feet
- 3" pipe vents up to 100 equivalent feet

Six Year Limited Warranty on Heat Exchanger and Tank, One Year on Parts

- For complete information, consult written warranty or contact GSW Water Heating.



Residential Gas Hybrid Water Heater

CAPACITY & DIMENSIONS

MODEL NUMBER	FIRST HOUR RATING GALLONS	RECOVERY 90°F RISE GALLONS	INPUT			MANIFOLD PRESSURE		ELECTRICAL CHARACTERISTICS		SHIPPING WEIGHT LBS/KGS
			BTU/HR	GAS TYPE	IN. WC	kPA	VOLTS/HZ	AMPERES		
GX-90N	189	121	100,000	NAT	4.2	1.05	120/60	2.5	198/90	

This gas-fired water heater is design certified by CSA International under American National Standard/CSA Standard for Gas Water Heaters ANSI Z21.10.3 • CSA 4.3 (current edition).

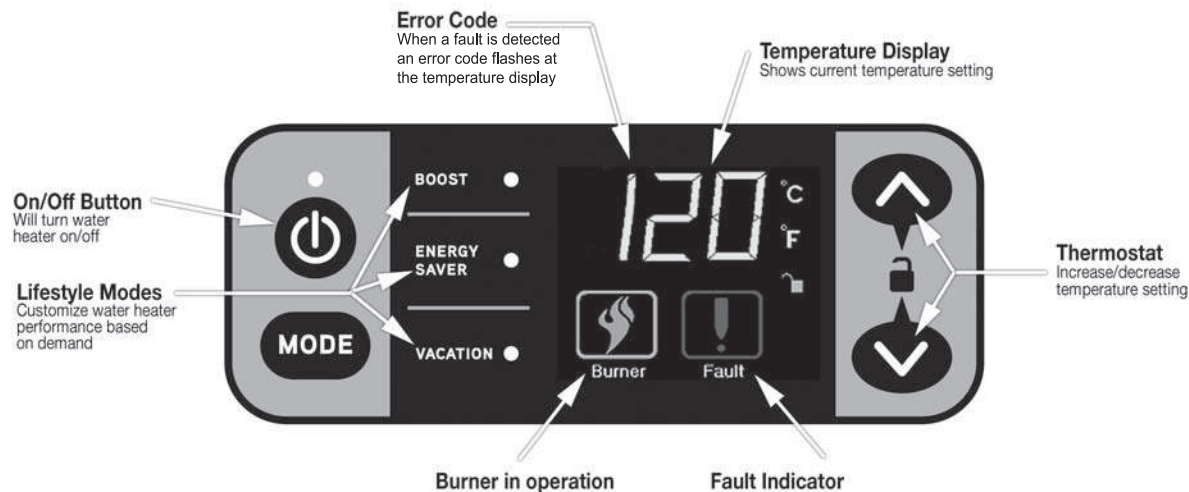
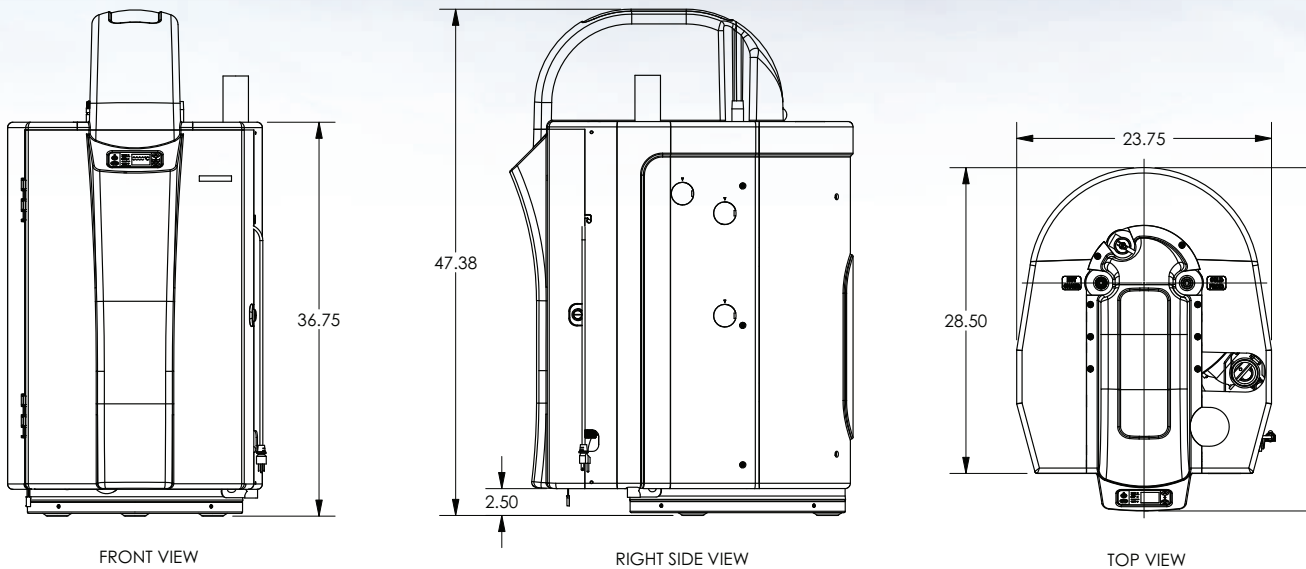

GSW Warranty:

All GSW and John Wood® Water Heaters will be replaced free of charge in the case of tank leakage within the stated warranty period from the date of installation in domestic applications, and one year in commercial applications. All parts supplied are warranted for one year. Warranty does not include labour. Consult owner's manual for complete details.

GSW Water Heating HEAD OFFICE:

599 Hill Street West
 Fergus, ON, Canada N1M 2X1
 Tel: 888-599-2837
 Fax: 519-787-5500
 E-mail: gswinfo@gsw-wh.com
www.gsw-wh.com

