



# INSTALLATION AND OPERATING INSTRUCTIONS

Read these instructions thoroughly before starting

## POWER VENTED GAS FIRED WATER HEATER

**⚠ WARNING:**

Improper installation, adjustment, alteration, service, or maintenance can cause injury or property damage. Refer to this manual. For assistance or additional information, consult a qualified installer, service agency, or the gas utility.

**⚠ FOR YOUR SAFETY**

- Do not store or use gasoline or other flammable vapours and liquids in the vicinity of this or any other appliance.
- Installation and service must be performed by a qualified installer, service agency or the gas utility.

**⚠ WARNING:**

If the information in these instructions is not followed exactly, a fire or explosion may result causing property damage, personal injury or death.

**WHAT TO DO IF YOU SMELL GAS**

- Do not try to light any appliance.
- Do not touch any electrical switch; do not use any phone in your building.
- Immediately call your gas supplier from a neighbor's phone. Follow the gas supplier's instructions.
- If you cannot reach your gas supplier, call the fire department.



Installation and service must be performed by a qualified installer, service agency or the gas supplier.

TABLE OF CONTENTS

<b>INTRODUCTION</b> .....	<b>3</b>	<b>SAFETY LOCKOUTS</b> .....	<b>22</b>
User Responsibilities	3	High Limit Controls	22
Qualified Installer Or Service Agency	3	Thermostat/Water Temperature	
<b>SAFETY</b> .....	<b>4</b>	Blower Exhaust Gas Limit Switch	
Safety Warning (Flammable Vapours)	4	Blower Air Pressure Switch	22
Safety Warning (Scalding)	4	Flammable Vapour Sensor	22
Safety Warning (Carbon Monoxide)	4	Resettable Lockout	22
Relief Valve Requirements (T&P)	5	Water Heater Operation	22
Flooding/Freezing/Fire Damage	5	Installation Checklist	23
<b>INSTALLATION</b> .....	<b>5</b>	<b>OPERATING INSTRUCTIONS</b> .....	<b>24</b>
Unpacking the Water Heater	5	Temperature Regulation	24
Location Requirements	5	Mixing Valves	24
In Earthquake Zones		Lighting Instructions	25
Closet Installations		Operating The Temperature Control System	26
Floor Surfaces		Gas Control Valve/Thermostat	
Clearances and Accessibility	6	<b>OPERATION</b> .....	<b>27</b>
Gas Supply	6	Burner Flames	27
Gas Supply Pressure		Operational Conditions	27
Gas Leak Testing		Condensation	
Gas Operating Pressures		Water Heater Sounds	
Air Requirements	7	Smoke/Odour	
Appliances In Enclosures	7	Anode Rod/Water Odour	
Typical Installation	8	“Air” In Hot-water Faucets	
Replacement Parts And Delimiting Products	9	<b>MAINTENANCE</b> .....	<b>28</b>
Water Piping - Mixing Valve Usage	10	Draining and Flushing	28
Mixing Valves		Routine Preventative Maintenance	
Exhaust Venting	11	(Homeowner/User)	28
High Ambient Temperature Installations	11	Gas Control	28
Important Notes and Warnings		Temperature and Pressure Relief Valve	28
Venting Terminations and Sizing		Burner Operation and Inspection	28
Rodent Screens		Burner Cleaning	
Termination Clearances Sidewall Power Vent		Housekeeping	29
Calculating Equivalent Feet		Anode Rod Inspection	29
Venting Instructions		To Remove the Anode Rod	
Blower Exhaust Direction	16	To Install the Anode Rod	
Blower Assembly Installation	16	Venting System and Blower	30
Vent Pipe Connection to Blower		<b>COMBO HEATING</b> .....	<b>31</b>
Condensate	18	System Requirements	31
Water Supply	18	Installation	31
Piping Installation		<b>TROUBLESHOOTING GUIDE</b> .....	<b>32</b>
Filling the Water Heater		Ignition State and Timing	34
Closed System/Thermal Expansion		System Error Codes	
Temperature and Pressure (T&P) Relief Valve	19	Honeywell Troubleshooting Chart - User Control	
The Temperature and Pressure Relief Valve:		<b>REFERENCE PARTS</b> .....	<b>36</b>
The Discharge Line/Relief Drain Tube:		Reference Parts Listing	36
Temperature-Pressure Relief Valve and Pipe		<b>LIMITED WARRANTY</b> .....	<b>38</b>
Insulation			
Electrical Supply	20		

RETAIN THESE INSTRUCTIONS IN A SAFE LOCATION FOR FUTURE REFERENCE

## **Your safety and the safety of others is very important.**

**We have provided many important safety messages in this manual and on your appliance. Always read and obey all safety messages.**



**This is the safety alert symbol.**

**This symbol alerts you to potential hazards that can kill or hurt you and others.**

**All safety messages will follow the safety alert symbol and either the word “DANGER” or “WARNING”.**



**DANGER**

**You can be killed or seriously injured if you don't immediately follow instructions.**



**WARNING**

**You can be killed or seriously injured if you don't follow instructions.**

**All safety messages will tell you what the potential hazard is, tell you how to reduce the chance of injury, and tell you what can happen if the instructions are not followed.**

## **INTRODUCTION**

**Thank you for purchasing a Flammable Vapour Ignition Resistant Power Vented Water Heater.** This water heater is designed to reduce the risk of flammable vapour related fires by shutting the burner down before flammable vapours get into the water heater combustion chamber. This is achieved by the means of the flammable vapour sensor. Properly installed and maintained, it will provide years of trouble free service. This gas-fired water heater has been developed to produce potable hot water for normal residential demands and may also be used in combination with space heating applications but not space heating only.

### **User Responsibilities**

This manual has been prepared to acquaint you with the installation, operation and maintenance of your gas fired water heater and provide important safety information in these areas. It is your responsibility to ensure that your water heater is properly installed and cared for.

**FAILURE TO FOLLOW THE INSTRUCTIONS IN THIS MANUAL MAY RESULT IN SERIOUS BODILY INJURY AND/OR PROPERTY DAMAGE. THOROUGHLY READ AND UNDERSTAND ALL INSTRUCTIONS BEFORE YOU ATTEMPT TO INSTALL, OPERATE OR MAINTAIN THIS HEATER.**

Installation and service requires trade knowledge in the areas of plumbing, electricity, venting, air supply and gas supply. Only a qualified service technician shall install or service this water heater.

Service to the Power Vent System should only be performed by a qualified service technician.

The manufacturer of this water heater will not assume any liability for any property damage, personal injury or death resulting from improper sizing, installation or failure to comply with these instructions.

### **Qualified Installer Or Service Agency**

Installation and service of this water heater requires ability equivalent to that of a Qualified Agency in the field involved. Installation skills such as plumbing, air supply, venting, gas supply and electrical supply are required in addition to electrical testing skills when performing service.

**Do not discard this manual. You or future users of this water heater will need it for reference.**

## SAFETY

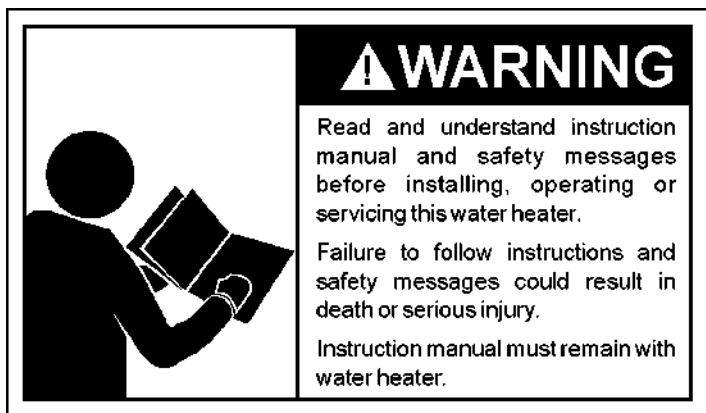

This water heater is design-certified by CSA International as a Category III, water heater that takes its combustion and dilution air either from the installation area or from air ducted to the unit from the outside.

In addition to the installation instructions found in this manual, the water heater must be installed in accordance with provincial codes and the latest edition of "**Natural Gas and Propane Installation Code**" CSA-B149.1.

### Safety Warning (Flammable Vapours)

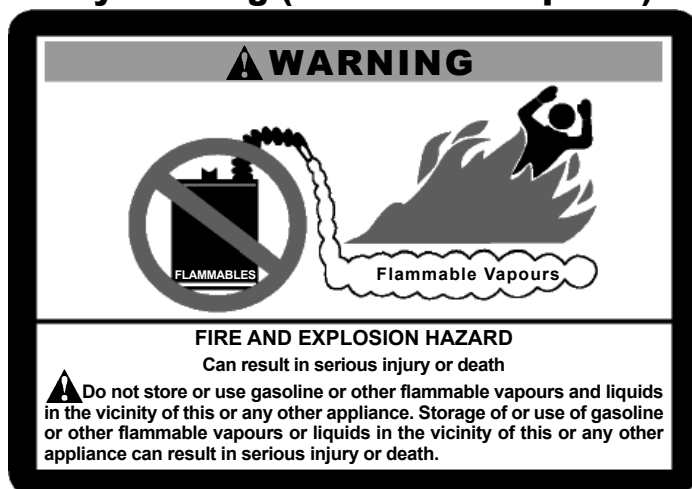

There is a risk of property damage, personal injury or death from the by-products of combustion (e.g., flue gases), in using fuel-burning appliances such as water heaters. Areas that may not be suitable for water heater installation include those where flammable liquids, gasoline, solvents, adhesives etc. are stored. Also not suitable are areas where engine-driven equipment is stored, operated or repaired. Flammable vapour products should not be stored or used near the water heater or air intake. Due to the nature of air movement, flammable vapours can be carried some distance from the point of storage. Although the safety system is designed to reduce the risk of flammable vapour related fires, the gas-fired water heater igniter or burner flame can ignite these vapours causing a flashback, fire or explosion, which may result in severe property damage, serious personal injury or death. If flammable liquids or vapours have spilled or leaked in the area of the water heater, leave the area immediately and call the fire department from a neighbor's home. Do not attempt to clean the spill until all ignition sources have been extinguished.

### Safety Warning (Scalding)

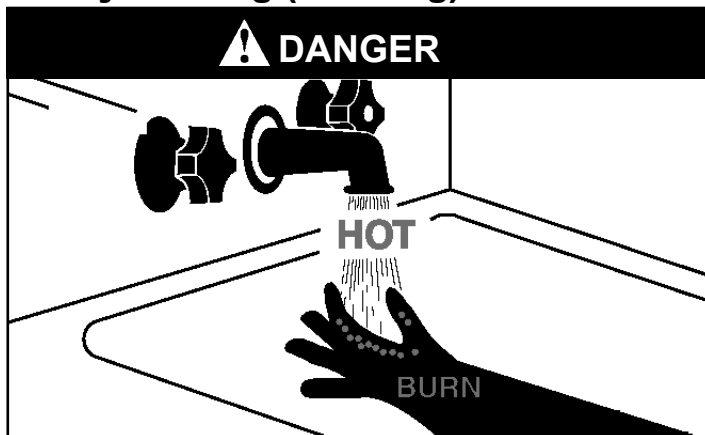

Hot water produced by this appliance can cause severe burns due to scalding. The hazard is increased for young children, the aged or the disabled when water temperatures exceed 52°C (125°F). Use tempering valves, also known as mixing valves, in the hot-water system to reduce the risk of scalding at point-of-use such as lavatories, sinks and bathing facilities (see Figures 11 & 12). Such precautions must be followed when this heater is operated in combination with dishwashing or space heating applications.

### Safety Warning (Carbon Monoxide)

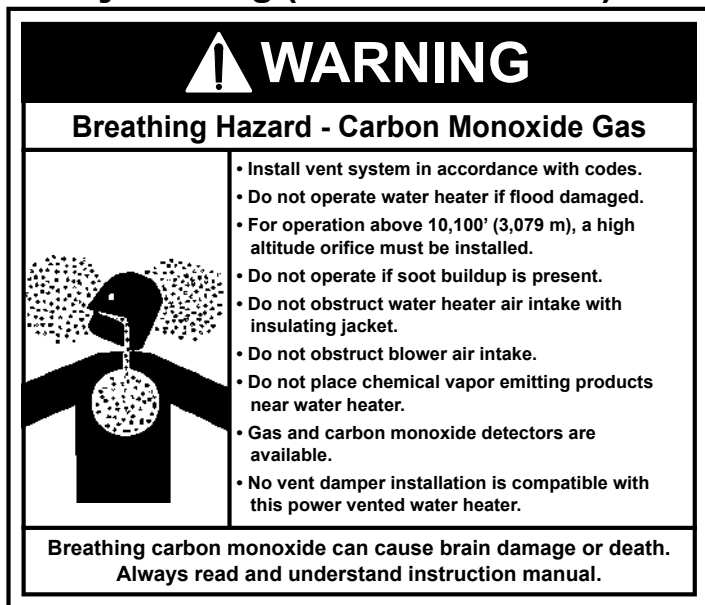

As with all fuel burning equipment, this heater requires an adequate supply of air for combustion. An insufficient air supply can result in poor combustion or the re-circulation of the flue gases. Such a condition may cause soot build-up and present a fire hazard. Flow reversal of flue gases may cause an increase of carbon monoxide inside of the dwelling that could result in serious bodily harm or death from asphyxiation.

**MAKE SURE THE FLOW OF COMBUSTION AIR IS NOT RESTRICTED.**

## Relief Valve Requirements (T&P)

All water heaters must be fitted with a proper temperature and pressure relief valve. These valves must be certified as meeting the requirements of the "Standard For Relief Valves For Hot Water Supply Systems, ANSI Z21.22/CSA 4.4".

## Flooding/Freezing/Fire Damage

If this water heater has been exposed to flooding, freezing, fire or any unusual condition, do not put it into operation until it has been inspected and approved by a qualified service technician. **THESE CONDITIONS CAN RESULT IN UNSEEN INTERNAL DAMAGE.**

### CAUTION

Hydrogen gas can be produced in a hot water system served by this heater that has not been used for a long period of time (generally two (2) weeks or more). **Hydrogen gas is extremely flammable and can ignite when exposed to a spark or flame.** To reduce the risk of injury under these conditions, it is recommended that the hot water faucet be opened for several minutes at the kitchen sink before using any electrical appliance connected to the hot water system. Use caution in opening faucets. If hydrogen is present, there will probably be an unusual sound such as air escaping through the pipe as the water begins to flow. There should be no smoking or open flame near the faucet at the time it is open.

## INSTALLATION

### Unpacking the Water Heater

**Important:** Do not remove any permanent instructions, labels, or the data label from outside of the water heater or on the inside of panels.

- Remove exterior packaging and place installation components aside.
- Inspect all parts for damage prior to installation and start-up.
- Completely read all instructions before attempting to assemble and install this product.
- Read the "Safety" section of this manual first and then entire manual carefully. If you don't follow safety rules, the water heater will not operate properly. It could cause DEATH, SERIOUS BODILY INJURY AND/OR PROPERTY DAMAGE. This manual contains instructions for installation, operation, and maintenance of the gas-fired water heater. It also contains warnings throughout the manual that you must read and be aware of. All warnings and instructions are essential to proper operation of the water heater and your safety. Since we cannot put everything on the first few pages, READ ENTIRE MANUAL BEFORE ATTEMPTING TO INSTALL OR OPERATE THE WATER HEATER.
- After installation, dispose of packaging material in the proper manner.

## Location Requirements

### IMPORTANT:

This water heater must be installed strictly in accordance with the instructions enclosed, and all applicable electrical, fuel and building codes. It is possible that connections to the water heater, or the water heater itself, may develop leaks. It is therefore strongly recommended that the water heater be installed so that any leakage of the tank or related water piping is directed to an adequate drain in such a manner that it cannot damage the building, furniture, floor covering, adjacent areas, lower floors of the structure or other property subject to water damage. This is particularly important if the water heater is installed in a multi-story building, on finished flooring or carpeted surfaces. **THE MANUFACTURER WILL NOT ASSUME ANY LIABILITY** for damage caused by water leaking from the water heater, pressure relief valve, or related fittings. Select a location as centralized within the piping system as possible. In any location selected, it is recommended that a suitable drain pan be installed under the water heater. This pan must limit the water level to a **MAXIMUM** depth of 45mm (1 3/4 in.) and have a diameter that is a minimum of 50mm (2 in.) greater than the diameter of the water heater. Suitable piping shall connect the drain pan to a properly operating floor drain. When used with a fuel-fired heater, this drain pan must not restrict combustion air flow.

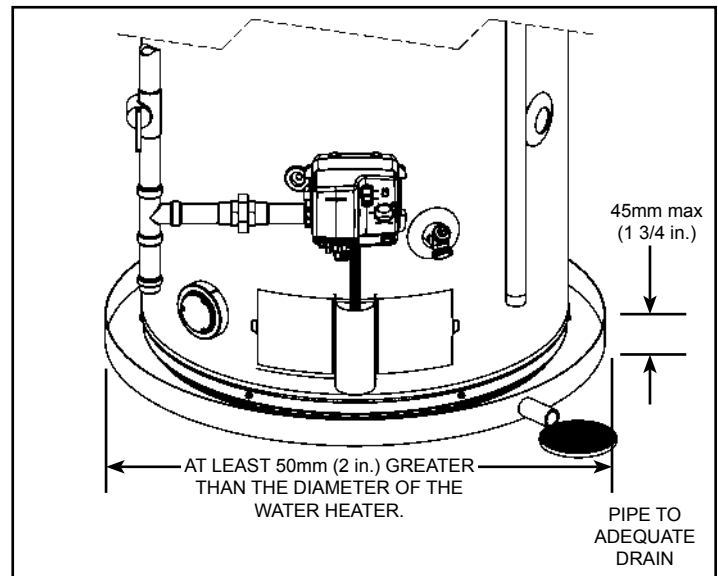

Figure 1

The water heater must be installed indoors in an area not subject to freezing temperatures and in a vertical position on a level surface. Water heaters located in unconditioned spaces (e.g., attics, basements etc.) may require insulation of the water piping, drain piping and venting to protect against condensation. The power vented series of water heaters are designed to vent the products of combustion horizontally through the wall or vertically through the roof. The blower expels the products of combustion by means of certified plastic piping to the outdoors without the need for a conventional chimney.

Select a location as centralized within the piping system as possible. The heater should be located in an area where leakage of the tank or connections will not result in damage to the area adjacent to the water heater or to lower floors of the structure (see "IMPORTANT" notice on the previous page). Before installing this water heater, consideration and planning must be given to the following details:

- Proximity to walls and other objects (see "Clearance and Accessibility").
- Access to gas supply (see "Gas Supply").
- Routing and support of the vent piping and termination (see "Venting").
- Position of water supply and placement of water piping and floor drain (see "Water Supply").

### In Earthquake Zones

The water heater must be braced, anchored, or strapped to avoid moving during an earthquake. Contact local utilities for code requirements in your area.

### Closet Installations

The water heater may be installed in a closet with a door that is connected to a bedroom or bathroom providing the units are installed and vented per the manufacturer's instructions.

### Floor Surfaces

If installing over carpeting, the carpeting must be protected by a metal or wood panel beneath the water heater. The protective panel must extend beyond the full width and depth of the water heater by at least 76mm (3 in.) in each direction or if in an alcove or closet installation, the entire floor must be covered by the panel.

### Clearances and Accessibility

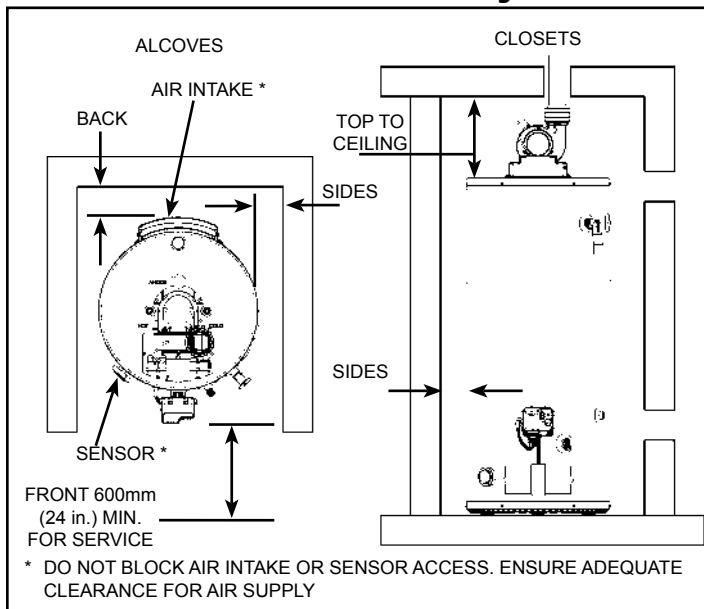

Figure 2

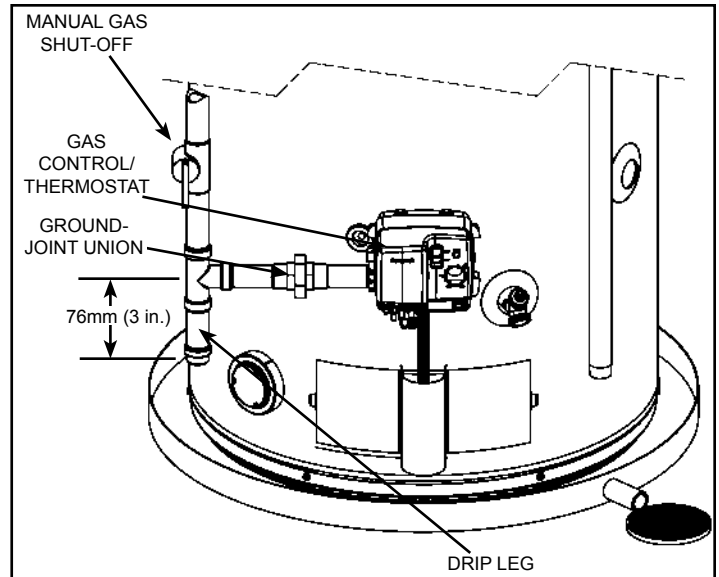

Figure 3

- The minimum clearances between the heater and combustible materials are:
 

Top	200mm (8 in.)
Front	100mm (4 in.)
Rear and Sides	0mm (0 in.)

**Note:** These requirements are also listed on the data plate located on the front of the water heater.

- The water heater is certified for installation on a combustible floor.

Figure 2 may be used as a reference guide to locate the specific clearance locations. A minimum of 600mm (24 in.) of front clearance and 100mm (4 in.) on each side should be provided for inspection and service.

### Gas Supply

**⚠ DANGER**

**Explosion Hazard**

- Install a gas supply shut-off valve.
- Do not connect a natural gas water heater to a L.P. gas supply.
- Do not connect a L.P. gas water heater to a natural gas supply
- Failure to follow these instructions can result in death, an explosion or carbon monoxide poisoning.

**Read the data plate to be sure the water heater is made for the type of gas you will be using in your home.** This information will be found on the data plate located above the gas control valve. If the information does not agree with the type of gas available, do not install or attempt to start.

**Note:** An odourant is added by the gas supplier to the gas used by this water heater. This odourant may fade over an extended period of time. Do not depend upon this odourant as an indication of leaking gas.

This gas piping must be installed in accordance with all provincial requirements and the latest edition of "**Natural Gas and Propane Installation Code**" CSA-B149.1.

Use properly sized gas piping and to ensure full gas input and a properly sized gas supply regulator to ensure adequate gas supply pressure. The supply piping and regulator must be large enough to satisfy the requirements of all appliances connected to the gas service and when all appliances are operating simultaneously. Undersize piping and insufficient pressure can restrict the gas flow causing the water heater to perform poorly. Improperly sized piping may pose a safety hazard.

**Note:** When installing gas piping, apply sealing compounds approved for use with natural and propane gas.

1. Install a readily accessible manual shut-off valve in the gas supply line as required "**Natural Gas and Propane Installation Code**" CSA-B149.1. The owner/operator must be shown the location of this valve and be given instructions on how to use it to shut off the gas to the heater.
2. Install a drip leg (if not already incorporated as part of the water heater) as shown. The drip leg must be no less than 76mm (3 in.) long for the accumulation of dirt, foreign material, and water droplets.
3. Install a ground joint union, or other approved gas disconnect, between the gas control/thermostat and the manual shut-off valve. This is to allow easy removal of the gas control/thermostat.
4. Turn the gas supply on and check for leaks. Use a chloride-free soap and water solution (bubbles forming indicate a leak) or other approved method.

### Gas Supply Pressure

**Important:** The gas supply pressure must not exceed the maximum supply pressure as stated on the water heater's data plate.

### Gas Leak Testing

**Important:** This water heater and its gas connection must be leak tested before placing the appliance in operation.

- If the code requires the gas lines to be tested at a pressure exceeding 14 in. w.c. (3.5 kPa), the water heater and its manual shut-off valve must be disconnected from the gas supply piping system and the line capped.
- If the gas lines are to be tested at a pressure less than 14 in. w.c. (3.5 kPa), the water heater must be isolated from the gas supply piping system by closing its manual shut-off valve.

**⚠ WARNING**

**Exposure to a higher gas supply pressure may cause damage to the control, resulting in explosion or fire. Consult your local gas supplier and gas authorities. DO NOT PUT INTO SERVICE IF OVER-PRESSURIZATION HAS OCCURRED.**

### Gas Operating Pressures

The gas supply pressure and burner manifold pressure is listed on the data plate located on the front of the heater above the gas control/thermostat. Ensure the gas supply pressure to the water heater and the burner manifold pressure are properly adjusted while all appliances are in operation. Refer to Figure 35 for Honeywell Gas Control/Thermostat Details.

Rated Manifold Pressure. in. w.c. (kPa)	Min. Manifold Pressure. in. w.c. (kPa)	Max. Manifold Pressure. in. w.c. (kPa)
10 (2.48)	9.2 (2.28)	10.2 (2.53)
4 (0.99)	3.6 (0.89)	4.4 (1.09)

U.L. and CSA recognized fuel gas and Carbon Monoxide (CO) detectors are recommended in all applications and should be installed using the manufacturer's instructions and local codes, rules or regulations.

### Air Requirements

A gas water heater cannot operate properly without the correct amount of air for combustion. Do not install in a confined area such as a closet, unless you provide adequate air supply. Never obstruct the flow of dilution/ventilation air. If you have any doubts or questions at all, call your gas supplier. Failure to provide the proper amounts of air can result in a fire or explosion and cause death, serious bodily injury, or property damage. The combustion and dilution air inlets are shown in Figure 5.

**Important:** Air must not come from a corrosive atmosphere. Any failure due to corrosive elements in the atmosphere is excluded from warranty coverage.

Installations in or for certain places including, but not limited to, those listed below may require outdoor air for combustion and dilution to reduce the risk of chemical exposure. In these cases it is probably necessary to install a Power Direct Vent (PDV) water heater:

- Beauty shops, Photo processing labs
  - Buildings with indoor pools
  - Water heaters installed in some laundry, hobby or craft rooms
  - Water heaters installed near chemical storage areas
- In some cases, isolation of the water heater from corrosive environments may be required.

### Appliances In Enclosures

If the water heater is installed in an enclosure ensure an air supply is provided as required by the current edition of "**Natural Gas and Propane Installation Codes**" CSA-B149.1.

## Typical Installation

1. Vent Termination Elbow with Rodent Screen
2. \*Vent Pipe
3. \*Vent Pipe Coupling (if required)
4. \*Vent Pipe Elbow (long radius)
5. Limit Switch (see Figure 9)
6. T&P Valve
7. Diptube
8. Baffle Assembly
9. \* Discharge Pipe
10. Gas Control Valve/Thermostat (Honeywell)
11. Gas Valve Electronic Control Module And Cover (Honeywell)
12. Drain Valve
13. Outer Gas Door
14. Manifold Door Assembly (behind outer door) (see Figures 6 & 7)
15. \*Floor Drain
16. \*Metal Drain Pan
17. Flammable Vapour Sensor (under cover) (see Figure 8)
18. \*\*Combo Heating System Return Inlet (Optional)
19. Air Inlet Snorkel
20. \*\*Combo Heating System Supply Outlet (Optional)
21. Blower with Power Cord (see Figure 9)
22. Air Switch (inside box) (see Figure 9)
23. Junction Box (see Figure 9)
24. Junction Box Cover (see Figure 6)
25. Air Tubing (see Figure 9)
26. Rubber Coupling
27. Gear Clamp
28. Flue Collector
29. Hot-Water Outlet Nipple
30. Anode (under cap)
31. Cold-Water Inlet Nipple
32. Flexible Manifold Tube (see Figures 6 & 7)
33. Viewport (see Figures 6 & 7)
34. Flame Sensor Rod (see Figures 6 & 7)
35. Gas Orifice (see Figures 6 & 7)
36. Sheet Metal Burner (see Figures 6 & 7)
37. Gas Manifold (see Figures 6 & 7)
38. Hot-Surface Igniter (see Figures 6 & 7)
39. Manifold Door Gasket (see Figures 6 & 7)
40. Manifold Door (see Figures 6 & 7)
41. Two Piece Grommet With Clip (see Figures 6 & 7)
42. \*Inlet Water Shut-off Valve
43. \*Gas Supply\*
44. \*Main Manual Gas Shut-off Valve
45. \*Ground Joint Union (gas connection)
46. \*Sediment Trap/Dirt Leg
47. \*Union (water connection)
48. Rating Plate
49. \*\*\*Control Harness
50. \*Thermal Expansion Tank (required for all closed systems)

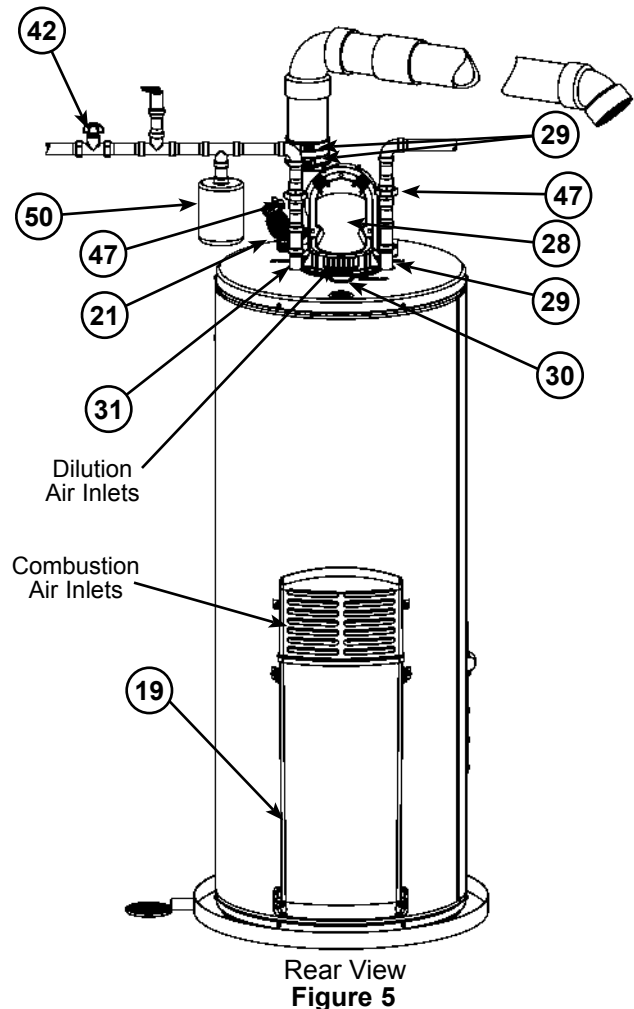
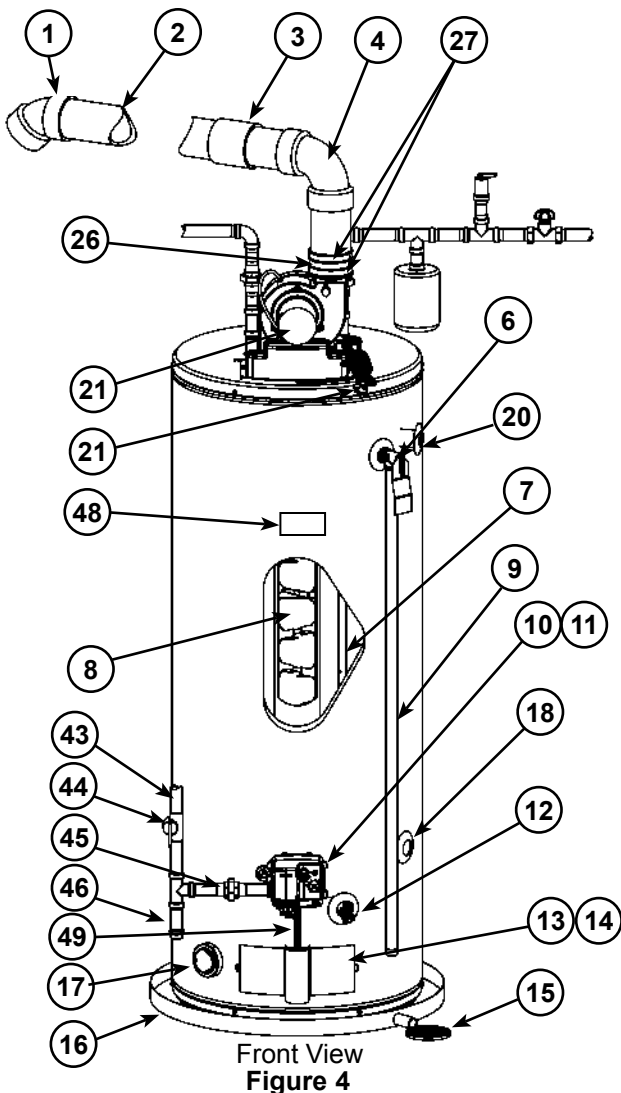



Natural gas and Propane main burner with igniter assembly for 40k to 50k Btu/hr models

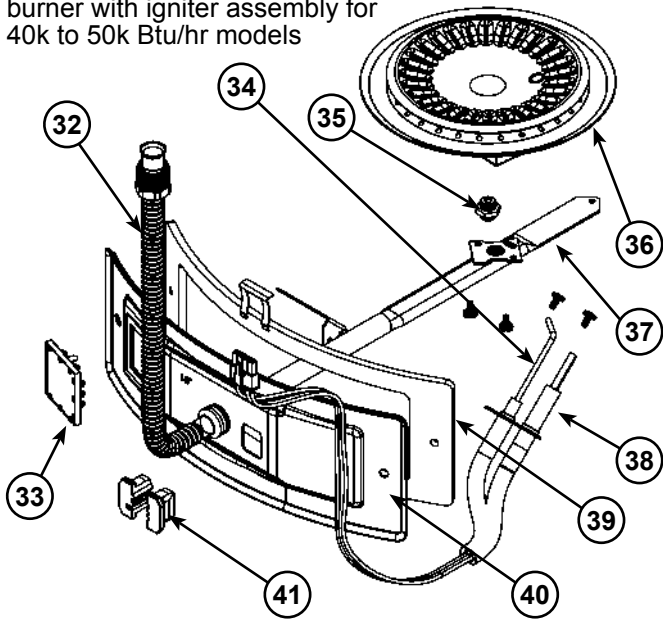

Figure 6

Natural gas and Propane main burner with igniter assembly for 60k to 75k Btu/hr models

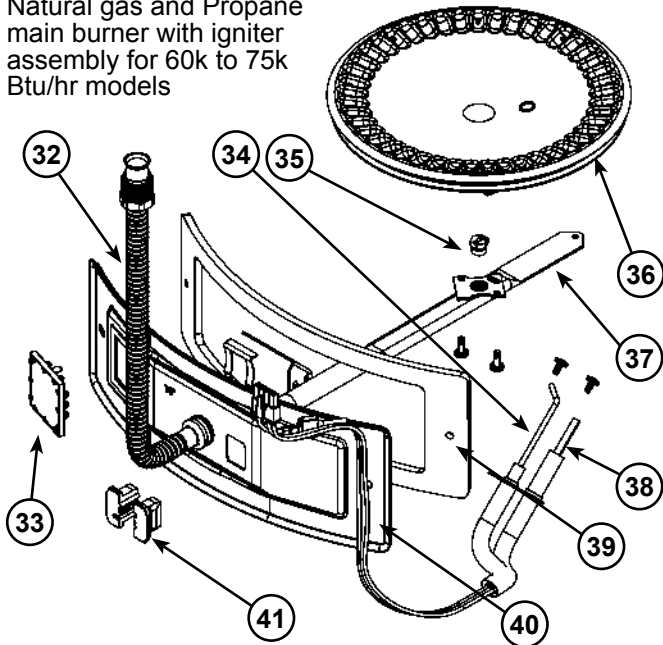

Figure 7

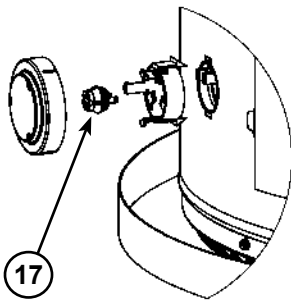

Figure 8

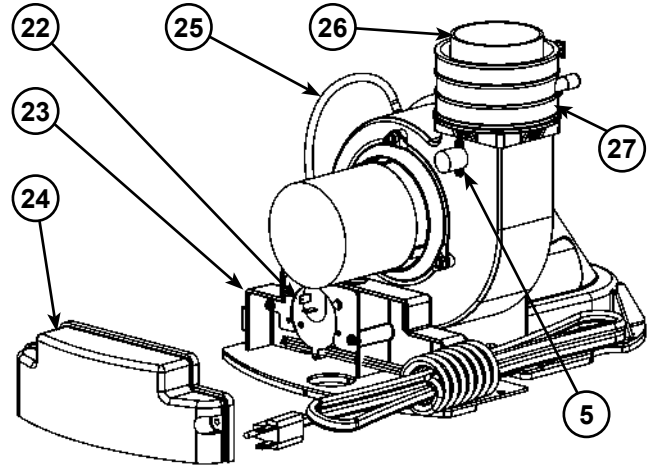

Figure 9

Vacuum relief valve install per local codes (not supplied with heater).

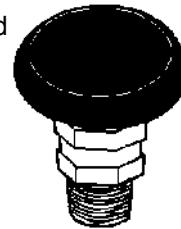

Figure 10

- \* Items not supplied with the water heater
- \*\* The side recirculation loop connections may not be used as the primary water inlet and outlet connections. For your convenience, plugs are installed in these fittings at the factory. Remove these plugs if needed for your specific installation. Otherwise (as with all connections) check for leaks while filling the tank with water and after completing the installation.
- \*\*\* **Caution:** harness has 120 VAC present during operation.

### Replacement Parts And Deliming Products

Replacement parts and recommended delimer may be ordered through authorized servicers or distributors. When ordering parts, provide complete model and serial numbers (see rating plate), quantity and name of part desired. Standard hardware items may be purchased locally.

## Water Piping - Mixing Valve Usage

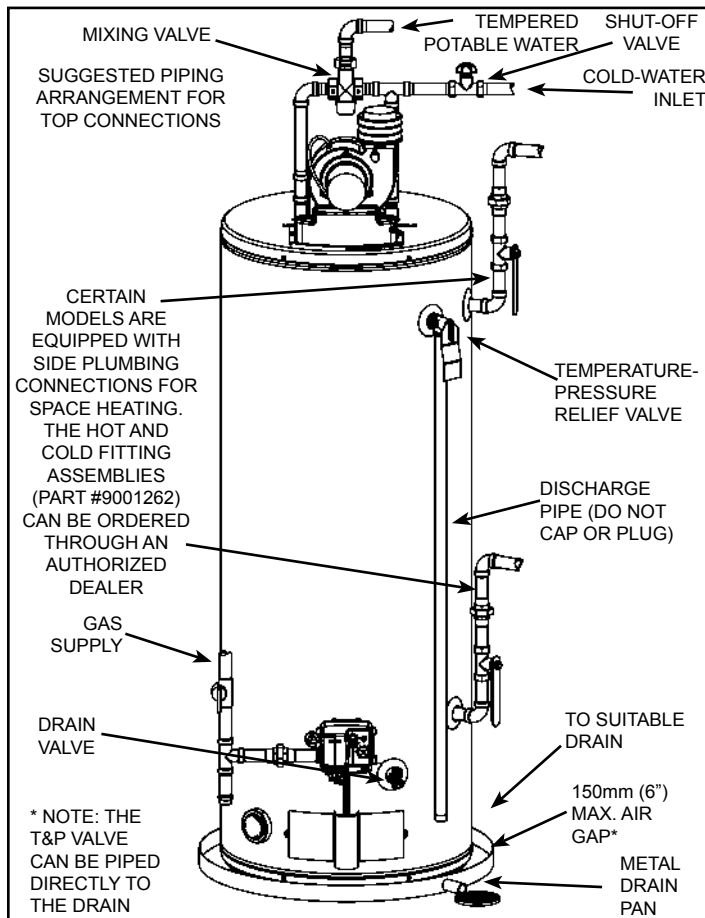

**Figure 11**

This appliance has been design certified as complying with CSA Standard for water heaters and certain models with side plumbing connections are considered suitable for Water (Potable) Heating and Space Heating.

The water heater should not be subjected to excessive water pressure fluctuations and should not be subjected to an operating pressure greater than 80 psi. If this occurs, a pressure-reducing valve with a bypass should be installed in the cold-water inlet line. This should be placed on the supply to the entire house in order to maintain equal hot and cold water pressure.

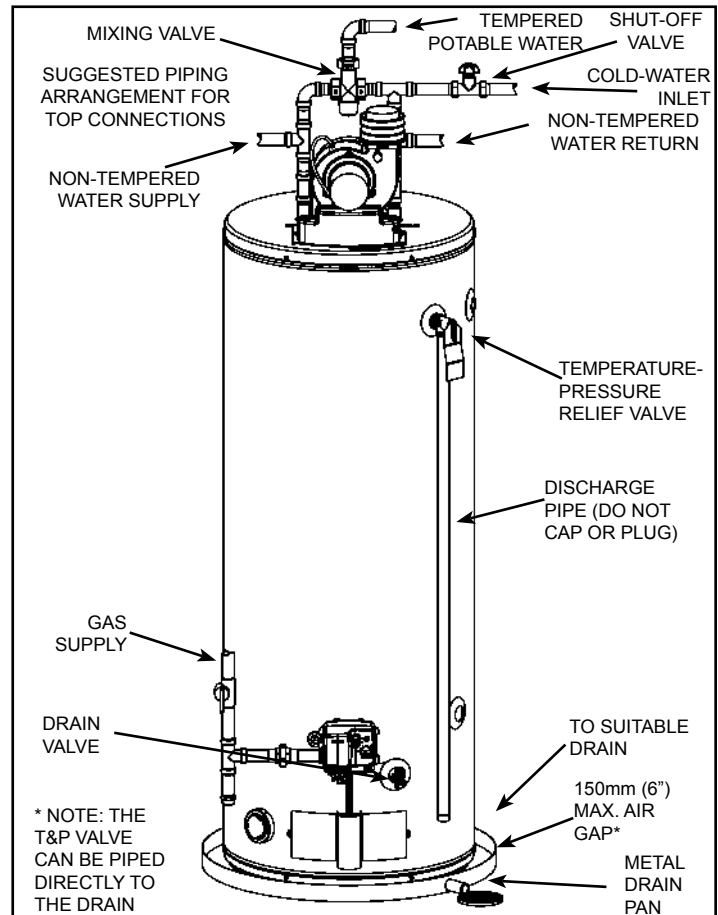

**Figure 12**

### Mixing Valves

Water heaters are intended to produce hot water. Water heated to a temperature which satisfies space heating, clothes washing, dish washing, and other sanitizing needs can scald and cause permanent injury upon contact. Short repeated heating cycles caused by small hot-water uses can cause temperatures at the point of use to exceed the water heater's temperature setting by up to 11C° (20F°).

Some people are more likely to be permanently injured by hot water than others. These include the elderly, children, the infirm and the physically/mentally disabled. Table 3 shows the approximate time-to-burn relationship for normal adult skin. National plumbing code requirements limit the temperatures of certain fixtures in the home. Local codes may have additional requirements. In addition to these requirements, if anyone using hot water in your home fits into one of these groups, then you must take special precautions. In addition to using the lowest possible temperature setting that satisfies your hot water needs, a means such as a Mixing Valve, should be used at the hot water taps used by these people or at the water heater. Mixing valves are available at plumbing supply or hardware stores. Consult a Qualified Installer or Service Agency. Follow mixing valve manufacturer's instructions for installation of the valves (see Figures 11 & 12). Before changing the factory setting on the thermostat, read the "Temperature Regulation" section in this manual.

## Exhaust Venting

This heater is designed to exhaust the products of combustion (flue gases) to the outdoors using a sealed piping system. Table 1 lists the allowable vent materials and sizing information. Figure 16 shows the general venting layout while Figures 17-19 show various end termination details and clearances. Connection of the venting piping to the blower is shown in Figures 21-25.

Correct installation of the venting system is essential to the safe and efficient operation of this water heater. Vent piping must be installed in accordance with all applicable national and provincial codes. All installations shall meet the requirements as stated in the latest edition of the **"Natural Gas and Propane Installation Codes" CSA-B149.1**.

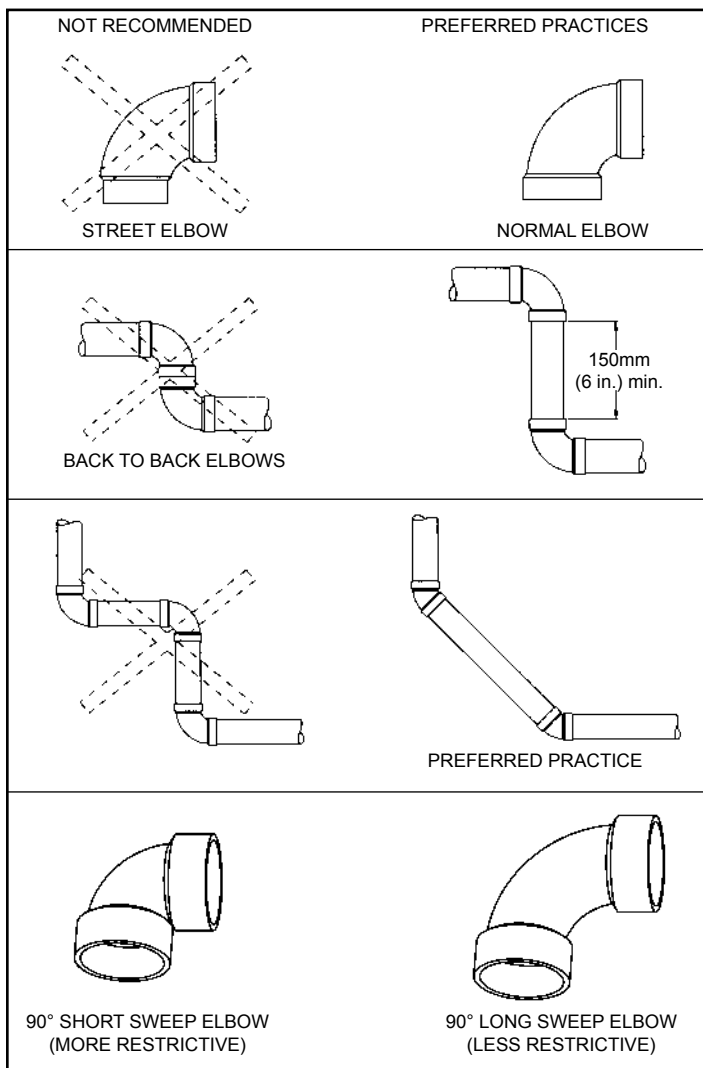

**Figure 13**

**Note:** The information provided in Figure 13 is intended as a guideline for good vent installation practices only and is not intended to restrict venting options beyond those restrictions established by the latest edition of the **"Natural Gas and Propane Installation Codes" CSA-B149.1** or any applicable local and provincial codes.

## High Ambient Temperature Installations

This heater requires room air to lower the flue gas temperatures before the gases pass through the vent system. The dilution air inlets are located on the rear of the blower assembly (see Figures 5 & 21). As the room temperature rises, the ability to lower the flue gases lessens so special attention to the choice of venting material is required. Establishing the ambient temperatures where the heater and the venting is installed is very important, especially in regions with warmer climates or any region that experiences hot summers. Ambient conditions hotter than 43°C (110°F) require that the venting material be either CPVC or polypropylene. Areas that can experience high ambient environments include closets, alcoves, areas under staircases, attics especially in metal roofed buildings, areas with restricted air movement, rooms with large solar gains, metal sheds, industrial or commercial enterprises and venting systems exposed to direct sunlight. For high temperature environments, obtain high limit switch upgrade Kit # 9008306015 and use the higher rated vent piping.

### Important Notes and Warnings

- This heater is certified to be installed using Schedule 40 PVC or CPVC or polypropylene plastic vent material. All jurisdictions require that this material is approved to ULC S636. Only use approved material. All venting material and components must be joined with the approved primer/cleaner and solvent cement.
- Do not common vent this heater with any other appliance.
- During operation the plastic piping will expand as it heats up and contract as it cools down. This is normal for this type of venting. Rigidly fastening the vent piping can cause undue stress that may result in the cracking or fracturing the vent piping material. A fracture of the venting pipe may pose a serious safety hazard. To prevent stressing of the vent system, all hangers and supports must allow the vent piping freedom to move.
- Use long sweep elbows wherever possible. Closely-coupled elbows and short radius elbows can reduce the venting capacity.
- All power vented water heaters generate a certain amount of operational noise. In order to minimize noise transmission to the support structure, it is recommended to use isolation pads between the pipe hangers and the vent pipe.
- Most power vent installations develop some condensation in the vent piping. When using long runs of venting or when the venting passes through cold or unheated areas, considerable amounts of condensate from the flue gases can develop. Provision must be made for the condensate to drain freely from the system or to be collected in a condensate trap(s) that can be drained. Damage or fracture of the vent piping may occur if the condensate is allowed to collect and freeze. Pooling of condensate can restrict airflow and can cause nuisance failures of the system.

## Venting Terminations and Sizing

- Refer to Figure 16 and Table 1 for vent pipe materials and sizing. Examples of the vent terminations are shown in Figures 17 and 18. If the installation requires a vent riser, suitable drainage must be provided to ensure condensation does not accumulate. Termination through a roof is shown Figure 19.
- 40, 50 and 60-gallon heaters with rated inputs of 50k Btu/hr or less are supplied with a 2" termination elbow, a plastic "rodent screen" and a wire mesh "rodent screen" (see Figure 14).
- 50 and 75-gallon heaters with rated inputs of 60k Btu/hr or more are supplied with a 3" termination elbow, a plastic "rodent screen" and a wire mesh "rodent screen" (see Figure 15).

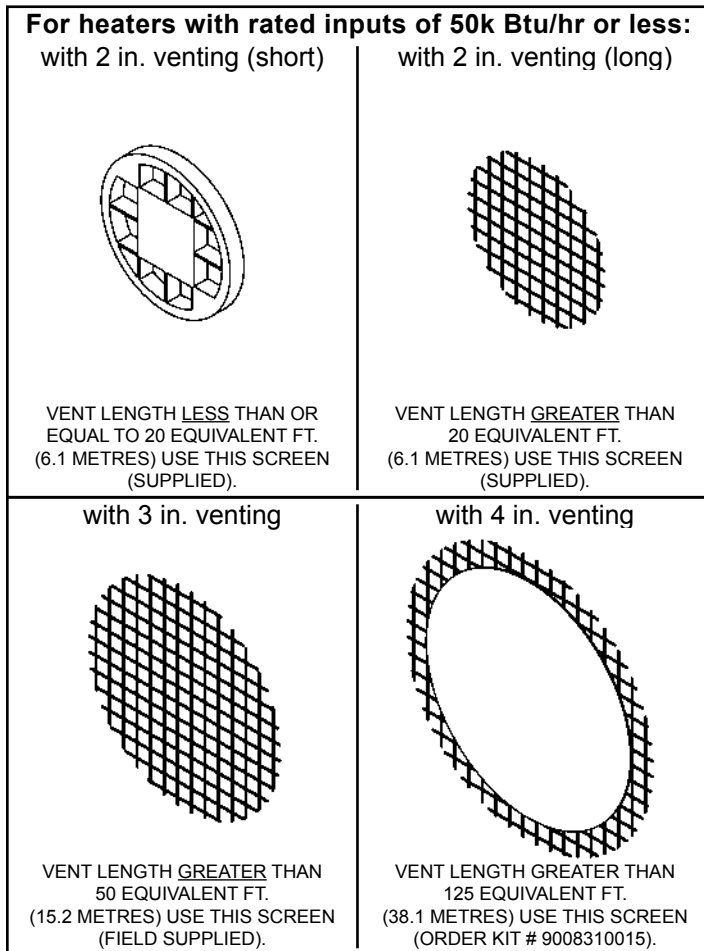

Figure 14

## Rodent Screens

A vent termination screen is required to keep foreign objects, rodents and small birds from entering the venting system. These screens have been sized to ensure maximum energy efficiency of the vent system based on the "equivalent length" of the vent piping. CHOOSE ONLY the ONE SCREEN THAT MATCHES YOUR VENTING CONFIGURATION (see Figures 14 & 15). How to determine the "equivalent length" is shown in Figure 16 and in Table 1. This will allow for easy removal for inspection and cleaning.

- For heaters with rated inputs of 50k Btu/hr or less see Figure 14.
- For heaters with rated inputs of 60k Btu/hr or more see Figure 15.

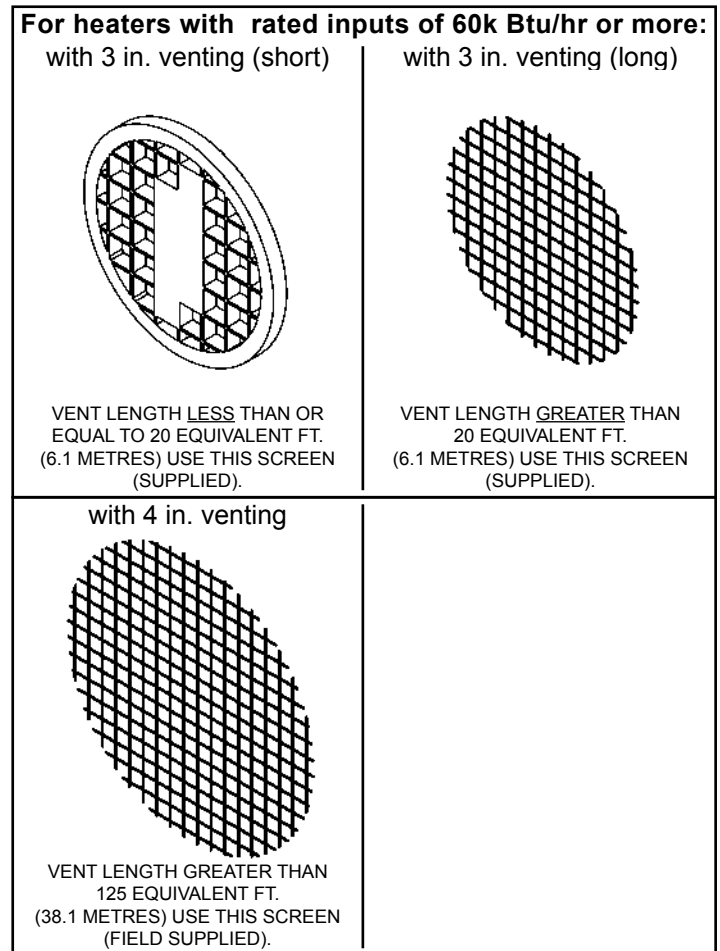

Figure 15

## Termination Clearances Sidewall Power Vent

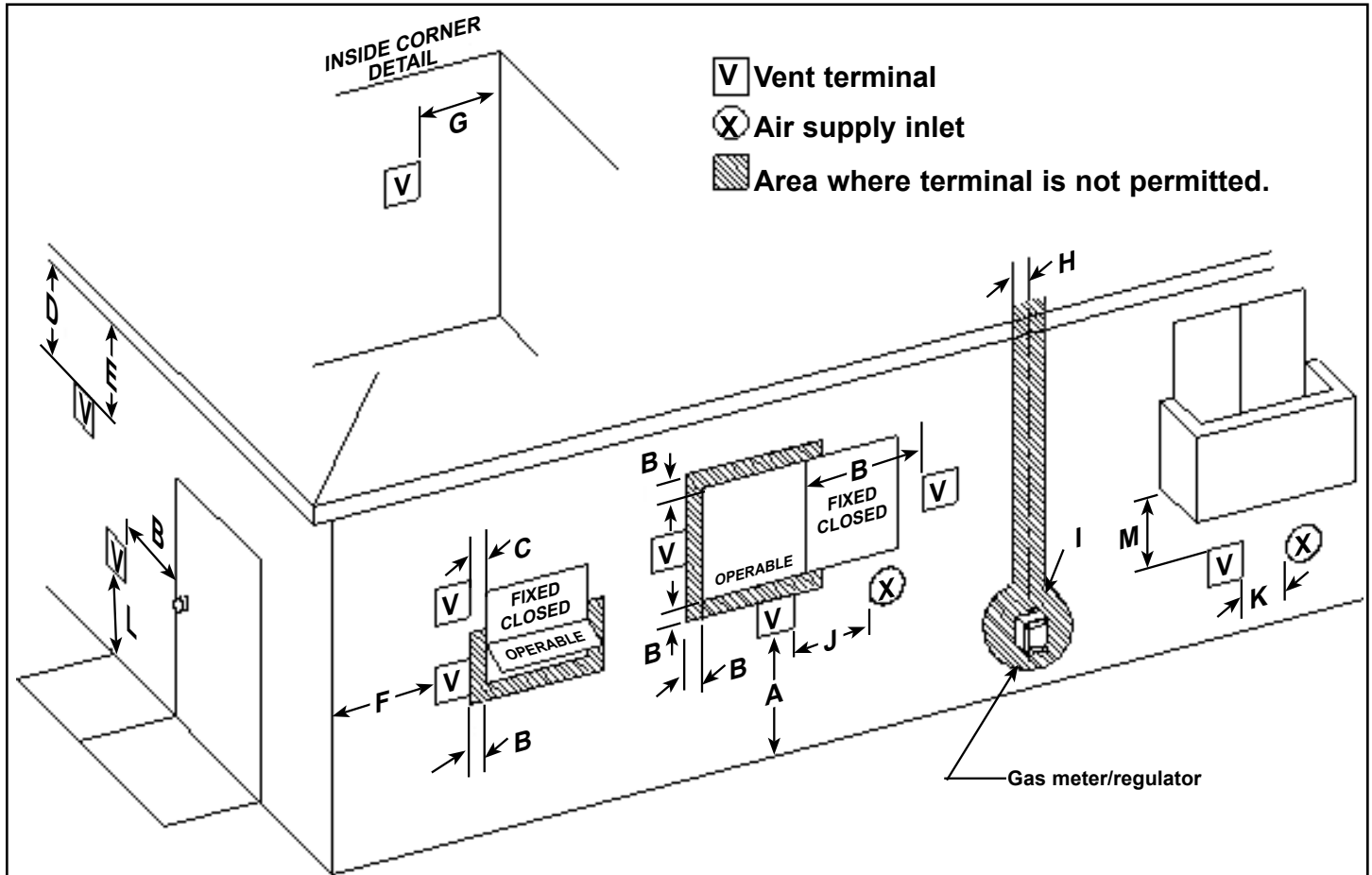

Figure 16a

Vent terminal clearances for "Power Vent" installations. Power Vent configurations use room air for combustion.

A	Clearance above grade, veranda, porch, deck, or balcony	12 in (30 cm)	I	Clearance to service regulator vent outlet	3 ft (1.83 m)
B	Clearance to window or door that may be opened	6 in (15 cm) for appliances ≤ 10,000 Btuh (3 kW), 12 in (30 cm) for appliances > 10,000 Btuh (3 kW) and ≤ 100,000 Btuh (30 kW), 36 in (91 cm) for appliances >100,000 Btuh (30 kW)	J	Clearance to nonmechanical air supply inlet to building or the combustion air inlet to any other appliance	6 in (15 cm) for appliances ≤ 10,000 Btuh (3 kW), 12 in (30 cm) for appliances > 10,000 Btuh (3 kW) and ≤ 100,000 Btuh (30 kW), 36 in (91 cm) for appliances >100,000 Btuh (30 kW)
C	Clearance to permanently closed window	*	K	Clearance to a mechanical air supply inlet	6 feet (1.83 m)
D	Vertical clearance to ventilated soffit located above the terminal within a horizontal distance of 2 feet (61 cm) from the center line of the terminal	*	L	Clearance above paved sidewalk or paved driveway located on public property	7 ft (2.13 m) †
E	Clearance to unventilated soffit	*	M	Clearance under veranda, porch deck, or balcony	12 in (30 cm) ‡
F	Clearance to outside corner	*	† A vent shall not terminate where it may cause hazardous frost or ice accumulations on adjacent property surfaces. ‡ Permitted only if veranda, porch, deck, or balcony is fully open on a minimum of two sides beneath the floor. * For clearances not specified in CSA-B149.1, one of the following shall be indicated: a) A minimum clearance value determined by testing in accordance with section 2.20, or; b) A reference to the following footnote: "Clearance in accordance with local installation codes and the requirements of the gas supplier."		
G	Clearance to inside corner	*			
H	Clearance to each side of center line extended above meter/regulator assembly	3 ft (91 cm) within a height 15 ft * above the meter/regulator assembly			

Table 1a

## Calculating Equivalent Feet

WATER HEATER MODEL	HEATER INPUT (Btu/hr)	VENT SIZE (Inside Diam.)	PRESSURE SWITCH SETTING	MAXIMUM EQUIVALENT VENT LENGTH	MINIMUM EQUIVALENT VENT LENGTH
40 & 50 gal.	40,000	2" (50mm)	- 0.27 in. w.c.	50 ft. (15.2m) + termination elbow	7 ft. (2.1m) + termination elbow
60 gal.	42,000		- 0.27 in. w.c.		
40 & 50 gal.	50,000		- 0.37 in. w.c.		
40 & 50 gal.	40,000	3" (76mm)	- 0.27 in. w.c.	125 ft. (38.1m) + termination elbow	50 ft. (15.2m) + termination elbow
60 gal.	42,000		- 0.27 in. w.c.		
40 & 50 gal.	50,000		- 0.37 in. w.c.		
50 gal. (short)	62,000	3" (76mm)	- 0.99 in. w.c.	50 ft. (15.2m) + termination elbow	7 ft. (2.1m) + termination elbow
75 gal.	72,000		- 0.99 in. w.c.		
40 & 50 gal.	40,000	4" (102mm)	- 0.27 in. w.c.	180 ft. (54.9m) + termination elbow	125 ft. (38.1m) + termination elbow
60 gal.	42,000		- 0.27 in. w.c.		
40 & 50 gal.	50,000		- 0.37 in. w.c.		
50 gal. (short)	62,000	4" (102mm)	- 0.99 in. w.c.	125 ft. (38.1m) + termination elbow	50 ft. (15.2m) + termination elbow
75 gal.	72,000		- 0.99 in. w.c.		

Equivalent lengths of straight pipe for various elbows using Schedule 40 PVC, CPVC and polypropylene.

Vent Pipe Size	Elbow Type	Short Sweep/ Short Radius	Long Sweep/ Long Radius	Notes:
2" 3" 4"	90°	8 ft. (2.44m)	5 ft. (1.52m)	<b>Notes:</b> 1. Use long radius elbows where possible. Minimum distance between 90° elbows should be 6" (150mm) wherever possible. 2. Venting systems may use a maximum of five (5) 90° elbows. 3. Use proper screen termination (see Figures 14 & 15).
2" 3" 4"	45°	4 ft. (1.22m)	2.5 ft. (0.76m)	

Table 1

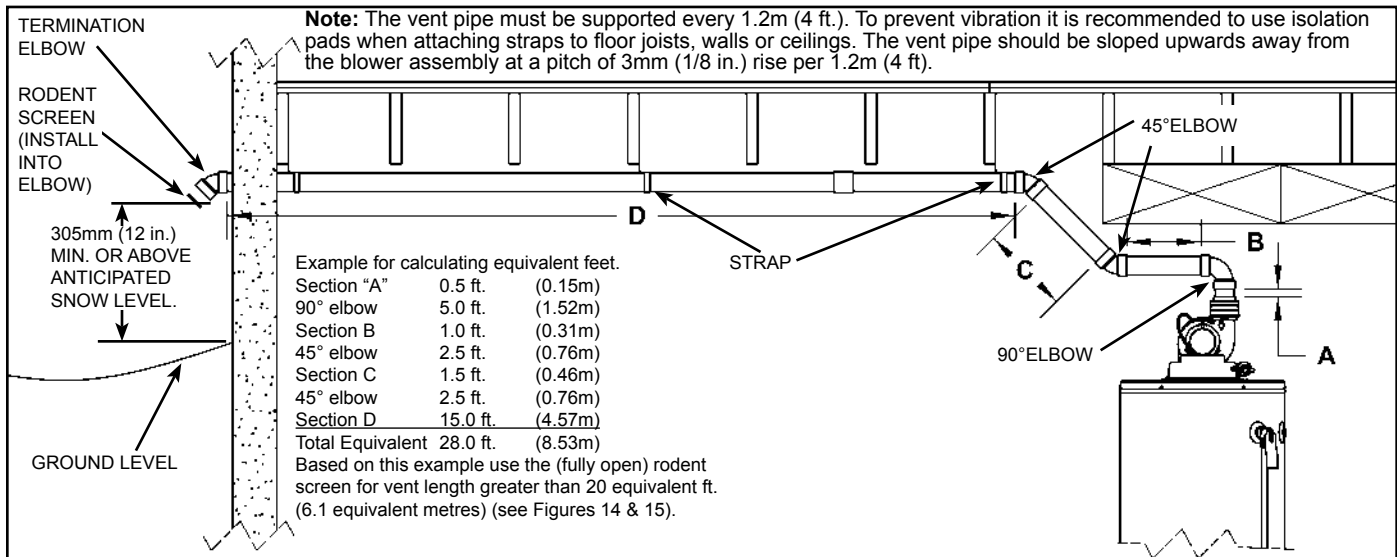

Figure 16

## Venting Instructions

1. Plan the venting layout starting at the vent termination and work back toward the heater. Take into consideration the style and position of the vent termination, the vent pipe routing, elbows and connectors required and the necessary support hangers.
2. 40, 50 and 60-gallon heaters may use 2 in., 3 in. or 4 in. venting depending on "Equivalent Vent Length" as described in Table 1. High input models require 3 in. or 4 in. venting. See also the section on "Vent pipe connection to blower".
3. Venting should be as direct as possible with the fewest number of fittings. Use long radius 45 degree and long radius 90 degree elbows wherever possible.
4. Avoid the use of 90 degree elbows "back to back" and do not use street elbows. Maintain a minimum 150mm (6 in.) straight section between elbows. Closely coupled and short radius elbows reduce the venting capacity. Figure 13 shows examples of vent pipe connections.
5. **DO NOT USE AN ELBOW AS A SUPPORT POINT.** Elbows are not designed to carry the weight of the venting system.
6. Calculate "Equivalent Vent Length" before starting. Do not exceed the values shown in Table 1. An example of how this length is determined is shown in Figure 16. The value from your calculations should also be used to determine which rodent screen to install into the vent termination elbow.
7. Follow the vent manufacturer's instructions for cutting and assembling the venting.
8. Provide support hangers for horizontal vent piping every 1.2m (4 ft.) to prevent sagging and stress. Provide a minimum of 3mm (1/8 in.) rise per 1.2m (4 ft.) of vent piping to ensure adequate drainage. Horizontal vent piping must not sag to form valleys where condensate may collect. Vertical venting shall be supported every 1.5m (5 ft.).



### CAUTION:

#### Use of Solvent Cement and Primer

- Use only in well-ventilated areas.
- Do not use near flame or open fire.
- Use only the Solvent Cement and Primer appropriate for the venting material being used.
- Solvent cements for plastic pipe are flammable liquids and must be kept away from all sources of ignition.

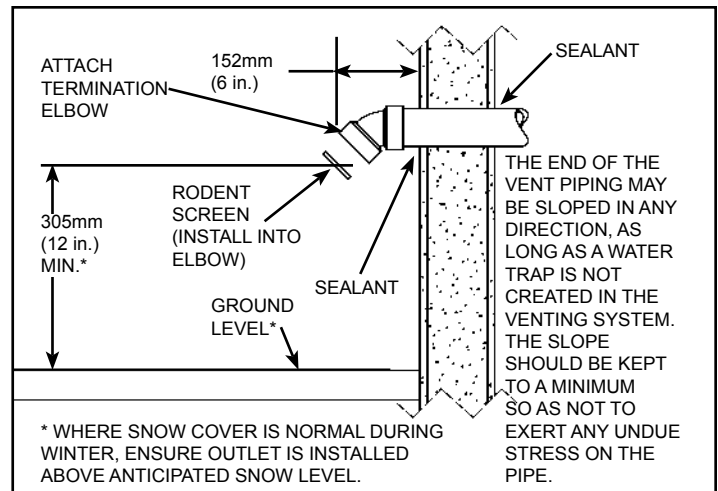

Figure 17

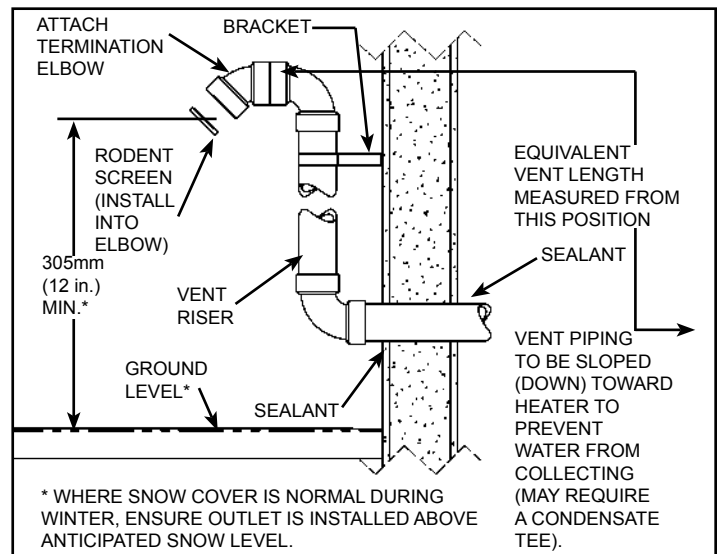

Figure 18

**Caution:** Solvent cements may produce flammable vapours. Use only in well-ventilated areas and keep away from all sources of ignition.

**Note:** Vapours produced by solvent cements can trigger the vapour sensor and lock-out the heater (see "Flammable Vapour Sensor" section).

9. Install the properly sized rodent screen into the outlet elbow and secure with a small quantity of silicone sealant (see "Rodent Screen" section).
10. Do not seal the vent piping to the wall until the venting is properly connected to the blower assembly.

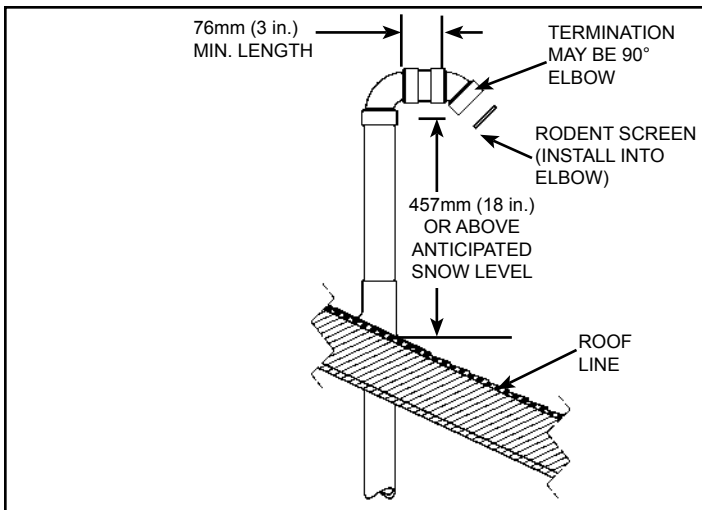

Figure 19

### Blower Exhaust Direction

The blower assembly may be rotated 90 degree clockwise or counterclockwise to allow horizontal venting in areas having restricted space above the water heater. To rotate the blower outlet, remove the four nuts (with 11/32" nut driver) (see Figure 20), securing the flue collector to the blower housing. Pull the blower assembly forward to free it from the mounting studs. Rotate the blower housing clockwise or counter-clockwise and align the four holes and screws together. Reattach the blower housing to the flue collector.

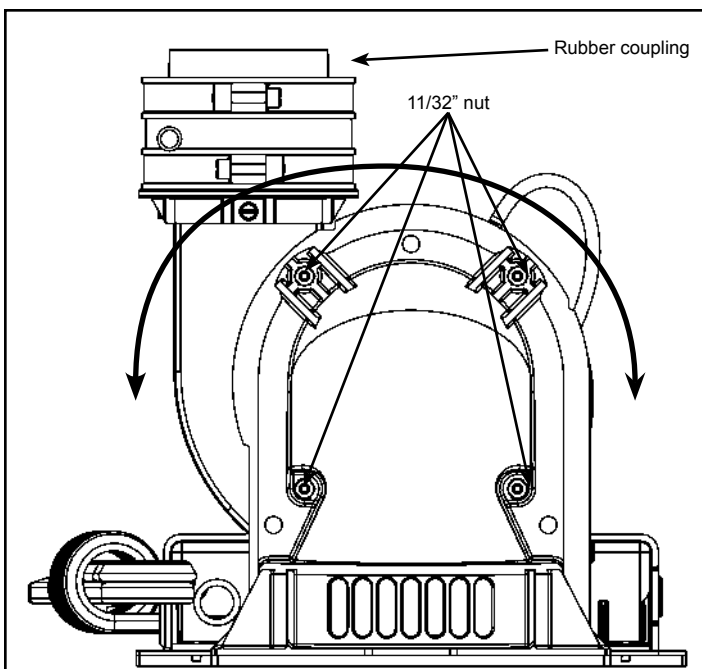

Figure 20

This power vent heater can accept 2" or 3" rubber coupling, depending on the capacity of the water heater. This coupling accepts the vent piping and is attached as shown in Figure 26. Refer to Figure 16 and Table 1 to determine vent pipe sizing for your application.

### Blower Assembly Installation

1. This power vented water heater comes with blower assembly installed (see Figure 26).
2. After unit is set in place, make sure blower assembly is still mounted securely. Make sure there is no damage to blower.
3. Make sure there is no packing material in the inlet or discharge of the blower.
4. Make sure that the plastic tubing is still attached from the air pressure switch to the port on the blower housing. Make sure the plastic tubing is not folded anywhere between the pressure switch and the blower housing.
5. This water heater is a polarity sensitive appliance and will not operate if the power supply polarity is reversed. Power to this water heater must be wired properly (correct polarity).
6. Do not plug in power cord until vent system is completely installed. The Power Vent operates on 110 -120 VAC. therefore a grounded outlet must be within reach of the 1.8m (6 ft.) flexible power cord supplied with the heater. The power cord supplied may be used on a unit only where local codes permit. If local codes do not permit use of flexible power supply cord, install field wiring. To connect the heater to field wiring:
  - a. Make sure the unit is unplugged from the wall outlet. Remove the screw and open panel on the front of the junction box on the blower.
  - b. Install a suitable conduit fitting inside the enclosure.
  - c. Splice field wiring into existing wiring using code authorized method (wire nuts, etc).
  - d. Be certain that the neutral and line connections are not reversed when making these connections.
  - e. Ground heater properly. This water heater must be grounded in accordance with the latest edition of "**Canadian Electrical Code (CAN/CSA C22.1), Part I**" and/or local codes. These must be followed in all cases if hard wired.
  - f. Close the panel on the junction box. Make sure that the access panel is secured shut.
7. The blower discharge boot is made to accept only straight sections of 2" or 3" pipe. To start off with an elbow, a short section of the furnished pipe must be cut and glued into the end of the elbow that will mount on the discharge boot.



## Vent Pipe Connection to Blower

### ⚠ CAUTION:

- Do Not Overtighten The Top And Bottom Gear Clamps Of The Rubber Coupling.
- Do Not Apply Solvent Cement Or Silicone To The Rubber Coupling Connection.

1. The plastic vent piping connects into the rubber coupling located on the top of the blower assembly. This coupling includes gear clamps to connect the venting to the blower. These connections must be properly seated and tightened to prevent the leakage of flue gases into the area. See Figures 21-25.
2. The 40, 50 and 60-gallon heaters with rated inputs of 50,000 Btu/hr or less are designed and supplied with a 51mm (2 in.) rubber coupling to accept the vent pipe.
3. The 50 and 75-gallon models with rated inputs of 60,000 Btu/hr or more are supplied with a 76mm (3 in.) rubber coupling to accept the vent pipe.
4. Before installing clean and lightly sand the end of the plastic vent piping that will connect into the rubber coupling.
5. Loosen the upper clamp on the rubber coupling and insert the sanded end of the vent piping a full 32mm (1-1/4 in.). Do not use glue or sealant in the rubber coupling. Check that there is no stress on the connection or the vent piping that may be caused by twisting or bending.
6. Tighten the upper clamp so that the vent piping is firmly secured in the coupling and is gas tight. Do not over tighten or cause distortion of any of the parts. Ensure the bottom of the rubber coupling is firmly seated on the blower outlet and that the lower gear clamp is also secure. Check to ensure there is no distortion or movement of the clamped assembly once it is completed.

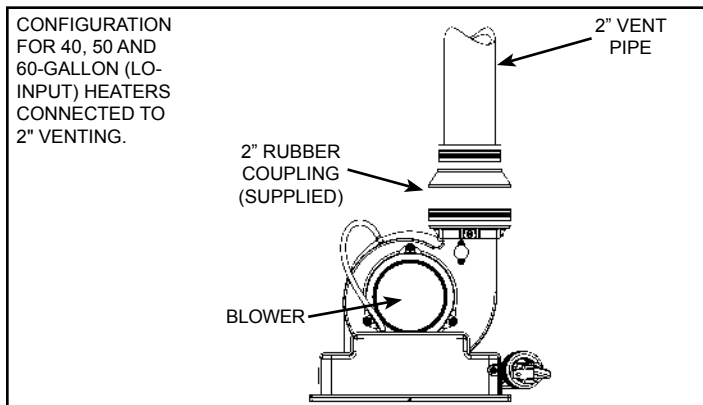

Figure 21

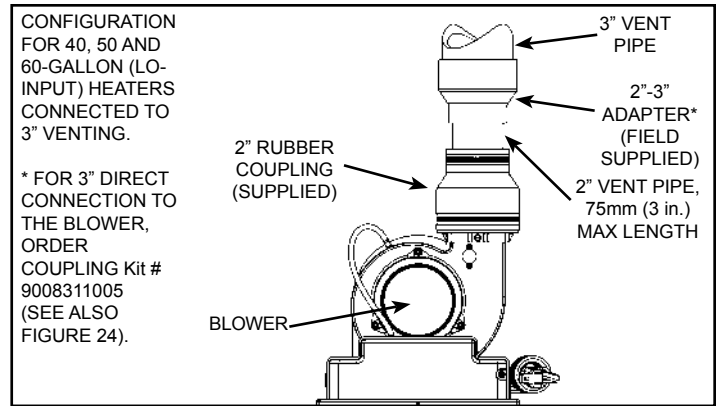

Figure 22

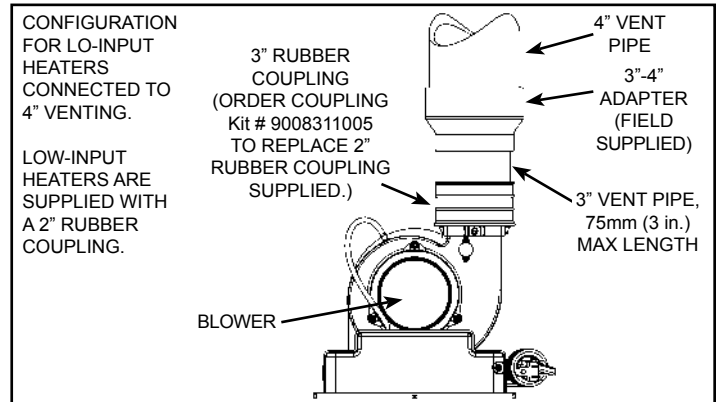

Figure 23

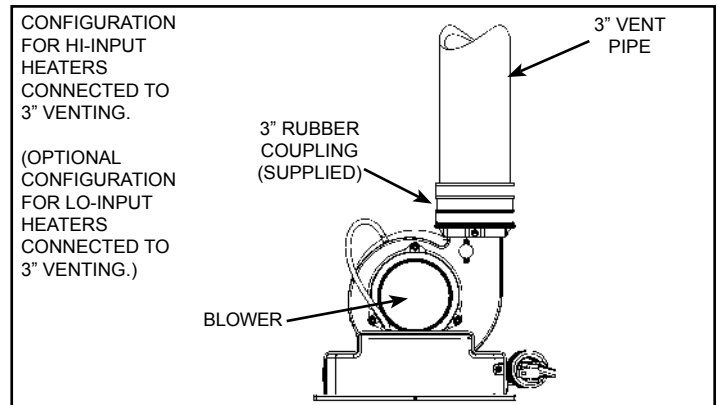

Figure 24

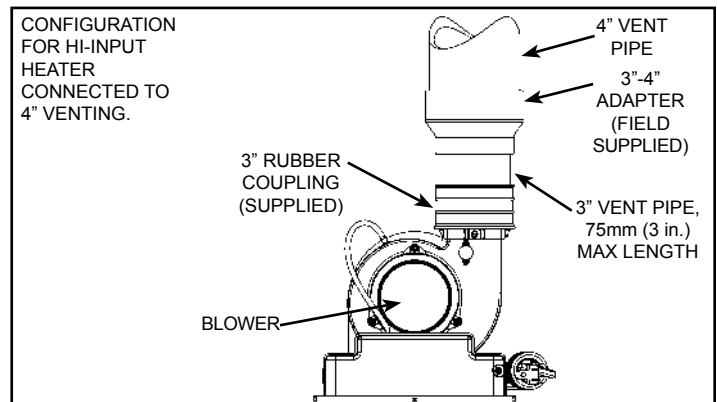

Figure 25

## Condensate

Condensate formation does not occur in all installations of power vented water heaters, but should be drained on installations where it can form in the venting system. Condensation in the venting system of power vented water heaters is dependent upon installation conditions including, but not limited to ambient temperature and humidity of installation location, ambient temperature and humidity of venting space, vent discharge and slope, and product usage. In certain conditions, installations in unconditioned space or having long horizontal or vertical vent runs can accumulate condensate. Long lengths of venting that pass through cool/cold areas will experience condensation. The vent pipe should be sloped upwards away from the blower assembly, then adequate means for draining and disposing of the condensate needs to be made by the installer. If installation conditions cause condensation, install a condensate trap loop approximately 200mm (8 in.) in diameter using 3/8" plastic hose. Connect the hose to the built-in drain port of the rubber coupling of the blower assembly (see Figure 26). Loop the hose in a vertical position as shown. The tube loop must be filled with water at least half way prior to operating the heater. Ensure the end of the tube has access to a drain as condensate will flow from the end. Secure the tubing to the side of the heater. Prior to operating the water heater, make sure the removable cap is installed on the drain port (if a drain hose is not needed). **Note:** This cap must remain in place if a drain hose is not installed.

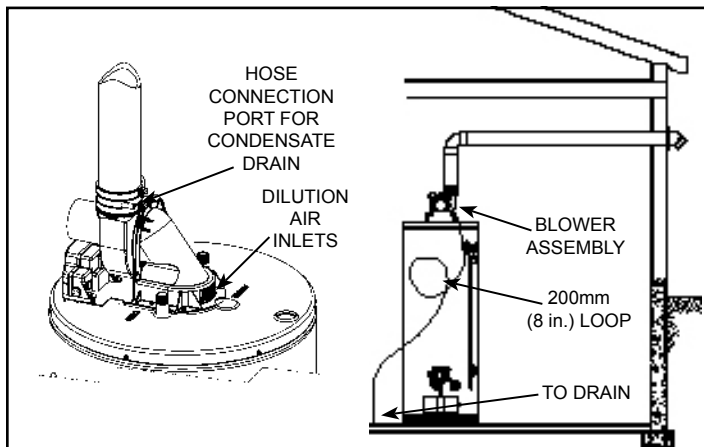

Figure 26

## Water Supply

### Piping Installation

Piping, fittings, and valves should be installed according to the installation drawing (Figure 27). Water supply pressure should not exceed 550 kPa (80psi). If this occurs a pressure reducing valve and/or an expansion tank may be required. The pressure reducing valve should be placed on the supply to the entire house in order to maintain equal hot and cold water pressures.

### Important:

- Do not apply heat to the water fittings on the heater as they may contain nonmetallic parts. If solder connections are used, solder the pipe to an adapter before attaching the adapter to the hot and cold water fittings.
  - All models contain energy saving heat traps to prevent the circulation of hot water within the pipes.
  - Always use a proper grade of joint compound and be certain that all fittings are drawn up tight.
1. Install the water piping and fittings as shown in Figure 27. Connect the cold water supply to the fitting (3/4" NPT) marked "COLD" (or "C"). Connect the hot water supply to the fitting (3/4" NPT) marked "HOT" (or "H").
  2. The installation of unions in both the hot and cold water supply lines is recommended.
  3. The manufacturer of this water heater recommends installing a tempering valve in the domestic hot-water line as shown in Figure 28. These valves reduce the point-of-use water temperature by mixing cold and hot water.
  4. If installing the water heater in a closed water system, install an expansion tank in the cold water line as specified under "Closed System/Thermal Expansion".
  5. Install a shut-off valve in the cold-water inlet line. It should be located close to the water heater and be easily accessible. The owner/operator must be shown the location of this valve and be given instructions on how to use it to shut off the water to the heater.

## Filling the Water Heater

Do not insert the power cord into the electrical receptacle until all the following steps have been completed.

1. Make sure the drain valve is closed.
2. Open a nearby hot-water faucet served by the system to allow air to escape from the tank.
3. Open the cold-water inlet valve.  
**Note:** When filling, avoid water leakage. Do not allow the insulation of the water heater to get wet as water can reduce the effectiveness of the insulation.
4. When an uninterrupted stream of water, without apparent air bubbles, flows from the open hot-water faucets, the tank is full.
5. Close the hot-water faucets and check the system for leaks. Repair as required and retest.

Please note the following:

The system should be installed only with piping that is suitable for potable (drinkable) water.

**DO NOT** use any pumps, valves, or fittings that are not compatible with potable water.

**AVOID** use of valves that may cause excessive restriction to water flow. Use full flow ball or gate valves only.

**DO NOT** use any lead based solder in potable water lines. Use appropriate tin-antimony or other equivalent material.

**DO NOT** tamper with the gas control/thermostat, igniter, flammable vapour sensor or temperature and pressure relief valve. Tampering voids all warranties. Only a qualified service technician should service these components.

**DO NOT** use with piping that has been treated with chromates, boiler seal, or other chemicals.

**DO NOT** add any chemicals to the system piping which will contaminate the potable water supply.

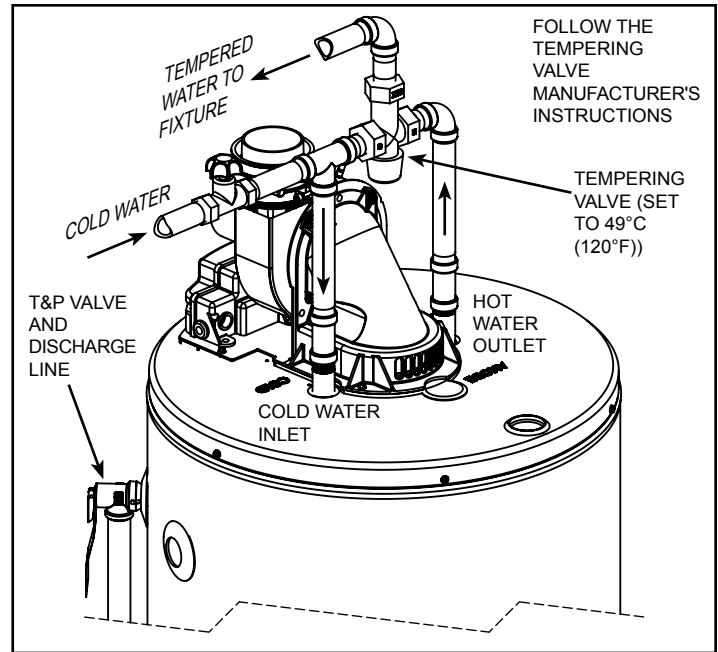

Figure 28

## Closed System/Thermal Expansion

Water supply systems may, because of code requirements or such conditions as high line pressure, among others, have installed devices such as pressure reducing valves, check valves, and back flow preventers. Devices such as these cause the water system to be a closed system. As water is heated, it expands (thermal expansion). In a closed system the volume of water will grow when it is heated. As the volume of water grows there will be a corresponding increase in water pressure due to thermal expansion. Thermal expansion can cause premature tank failure (leakage). This type of failure is not covered under the limited warranty. Thermal expansion can also cause intermittent Temperature-Pressure Relief Valve operation: water discharged from the valve due to excessive pressure buildup. This condition is not covered under the limited warranty. The Temperature-Pressure Relief Valve is not intended for the constant relief of thermal expansion. A properly sized thermal expansion tank must be installed on all closed systems to control the harmful effects of thermal expansion. Contact a local plumbing service agency to have a thermal expansion tank installed.

**Important:** Do not plug or remove the temperature and pressure (T&P) relief valve.

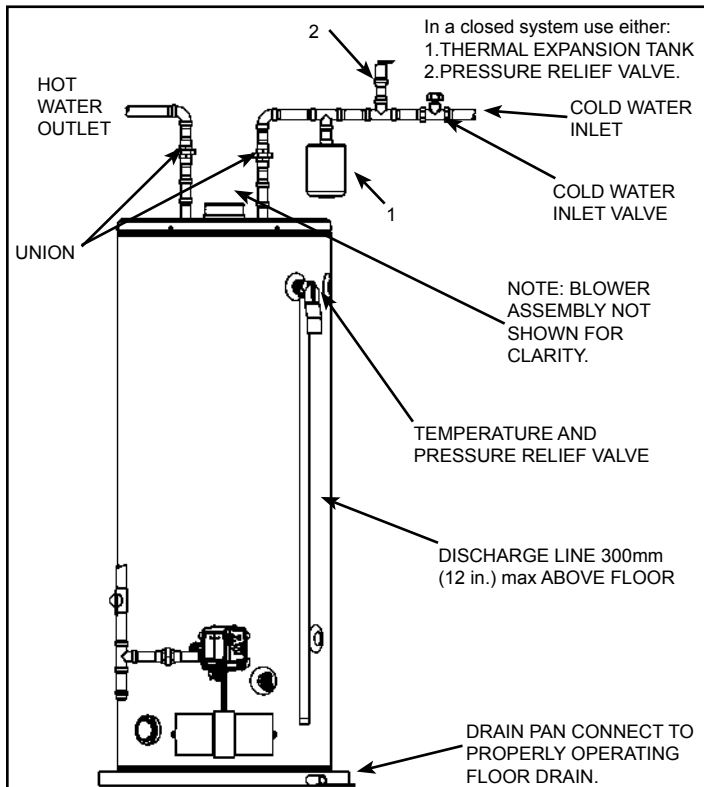

Figure 27

## Temperature and Pressure (T&P) Relief Valve

For protection against excessive pressures and temperatures, a temperature and pressure relief valve must be installed in the opening marked "T&P RELIEF VALVE" (see Figure 30). This valve must be design certified to meet the requirements of the "Standard For Relief Valves For Hot Water Supply Systems", ANSI Z21.22/CSA 4.4. The function of the temperature and pressure relief valve is to discharge water in large quantities in the event of excessive temperature or pressure developing in the water heater. The valve's relief pressure must not exceed the working pressure of the water heater as stated on the data plate.

**Important:** Only a new temperature and pressure relief valve (supplied) should be used with your water heater. Do not place any valve between the relief valve and the tank.

**The Temperature and Pressure Relief Valve:**

- Must not be in contact with any electrical part.
- Must be connected to an adequate discharge line.
- Must not be rated higher than the working pressure shown on the data plate of the water heater.

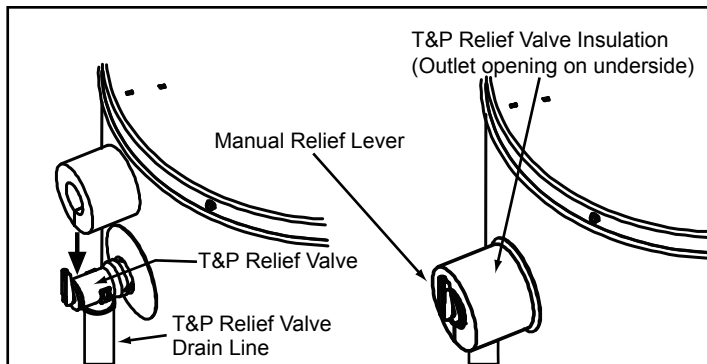

Figure 29

**⚠ WARNING**



**Explosion Hazard**

- If the temperature and pressure relief valve is dripping or leaking, have a licensed plumber repair it..
- Do not plug valve.
- Do not remove valve.
- Failure to follow these instructions can result in death or an explosion.

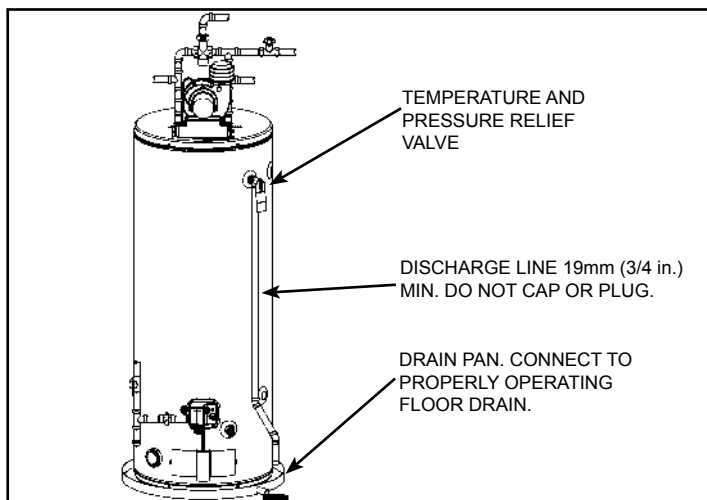

Figure 30

**The Discharge Line/Relief Drain Tube:**

- Must not be smaller than the pipe size of the relief valve or have any reducing coupling installed in the discharge line.
- Must not be capped, blocked, plugged or contain any valve between the relief valve and the end of the discharge line.
- Must terminate a maximum of 300mm (12 in.) above the floor.
- Must be capable of withstanding 121°C (250°F) without distortion.
- Must be installed to allow complete drainage of both the valve and discharge line.

The T&P valve shall be manually operated at least once a year. Caution should be taken to ensure that no one is in front of or around the outlet of the discharge line, and that the water manually discharged will not cause any bodily injury or property damage because the water may be extremely hot. If after manually operating the valve, it fails to completely reset and continues to release water, immediately close the cold-water inlet to the water heater, follow the draining instructions in this manual, and replace the temperature-pressure relief valve with a properly rated/sized new one.

**Temperature-Pressure Relief Valve and Pipe Insulation**

The T&P valve installed on this water heater is covered by insulation to minimize heat loss. The insulation has a hole on the bottom side to accommodate the valve outlet and allow for the piping connection. Do not restrict the outlet opening of the T&P valve.

**Electrical Supply**

**⚠ WARNING**

**Electrical Shock Hazard**



- Disconnect power before servicing.
- Replace all parts and panels before operating.
- Failure to do so can result in death or electrical shock.

**Important:** The electrical controls used inside the gas control/thermostat of this water heater are polarity sensitive. Ensure the electrical supply is connected correctly in the receptacle box. Failure to connect correctly will prevent the unit from functioning properly (see Figure 32). Before performing any electrical service work, label all wires to avoid connection errors. If wiring has to be replaced, use only **TYPE TEW 105°C** wire, (except igniter wires). If there is a problem with igniter wires, replace igniter assembly in its entirety. In locations where a sump pump failure, flooding or exposure to water may be present, a ground fault receptacle is recommended.

**Important:** Do not use an extension cord to connect the water heater to an electrical outlet.

- Ensure that the water heater and the outlet are properly grounded. Failure to properly ground the heater can prevent the unit from operating.
  - Ensure that the water heater is installed in accordance with prevailing provisions of the latest edition of **"Canadian Electrical Code (CAN/CSA C22.1), Part I"**.
- Before applying power to the water heater, always make sure:
- The voltage and frequency correspond to that specified on the water heater wiring diagram.
  - The electrical outlet has the proper overload fuse or breaker protection.
  - Fill the tank with water and check all connections for leaks. Open the nearest hot-water faucet and let it run for 3 minutes to purge the water lines of air and sediment and to ensure complete filling of the tank. If all the steps in the "Installation Checklist" have been completed, the electrical power may be turned on. Verify proper operation after servicing.

**Note:** Always reference the wiring diagram for the correct electrical connections.

**⚠ WARNING**

**When the unit is plugged in, 120VAC is present at the electric connections of the gas control/thermostat.**

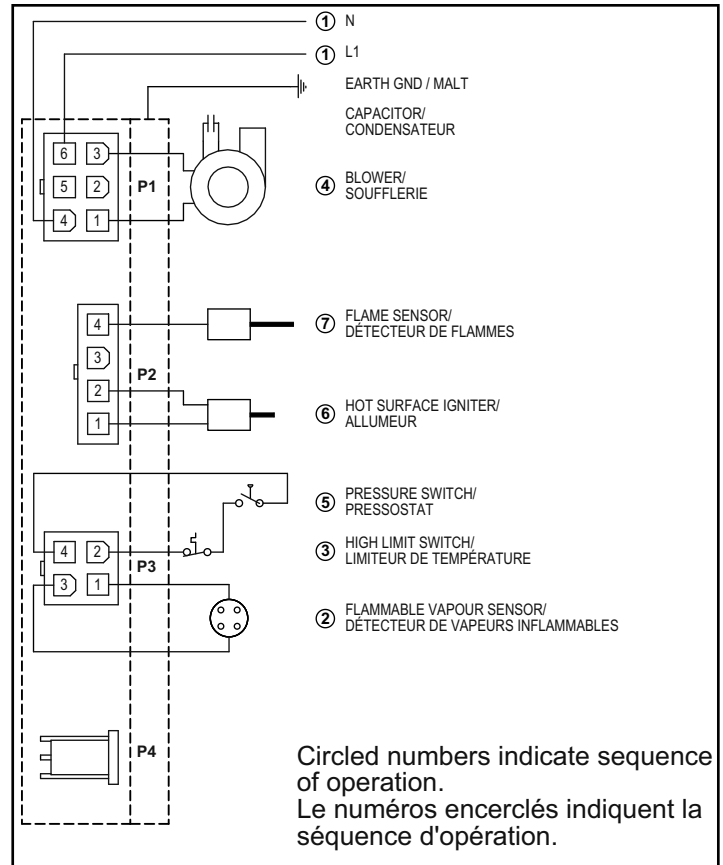

**Figure 31**

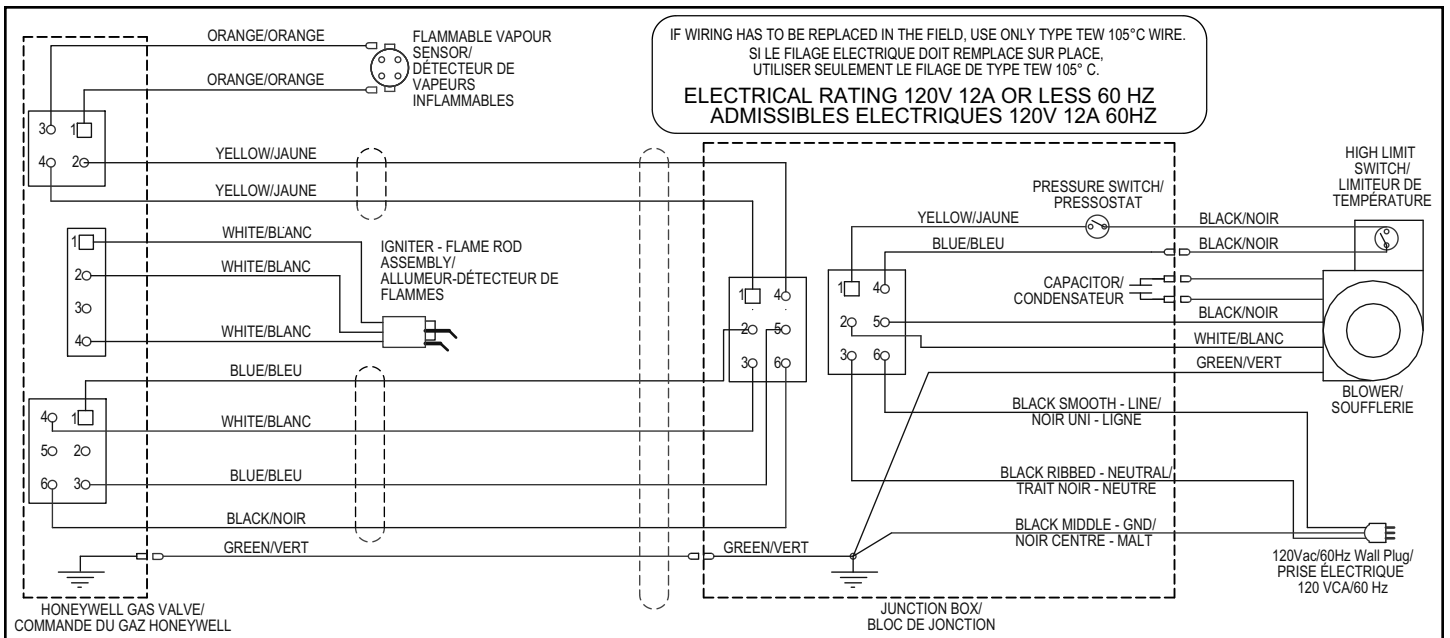

**Figure 32**

## SAFETY LOCKOUTS

This water heater has several lockout features designed to prevent the heater from operating in unsafe conditions.

### High Limit Controls

#### Thermostat/Water Temperature

This feature is a part of the gas control valve/thermostat (see Figure 35) and limits the maximum water temperature. In the event of the water overheating, this safety feature shuts off the fuel supply to the burner.

#### Blower Exhaust Gas Limit Switch

This device is located on the blower (see Item 5, Figure 9) and limits the maximum temperature of the blower. If the blower temperature rises above the temperature setting, the switch opens causing the heater to shut down. The switch will auto reset once the temperature drops sufficiently.

#### Blower Air Pressure Switch

This device, located in the junction box, monitors the air pressure produced by the blower. In the event that the exhaust venting becomes blocked or sufficiently restricted, the switch will shut the heater down (see Item 22, Figure 9).

### Flammable Vapour Sensor

When using a gas fired water heater there is a risk of flammable vapours entering the combustion chamber, being ignited by the burner flame and causing a flashback. In order to detect such flammable vapours before they enter the combustion chamber, this water heater is equipped with a flammable vapour sensor (FVS). It is a chemical-absorption based sensor that is connected to the gas control/thermostat (see Figure 33). When exposed to flammable vapours it will trigger the control to stop the flow of gas and enter the FVS lockout state. While in the FVS lockout state the LED on the control will flash the gas lockout code. (Refer to the "System Error Codes" section of this manual for an explanation of the codes applicable to the control installed on your water heater.) If this error occurs, check around the water heater for sources of chemical contamination such as: flammable vapours including gas vapours, solvents, paint and thinners as well as sources of water and detergents. Remove any such sources, check the surrounding area for damage and call a qualified service technician to service the water heater and replace the flammable vapour sensor. If there is a problem with the wiring of the flammable vapour sensor or the flammable vapour interface the LED will flash the failure status code (see Table 2 - "System Error Codes").

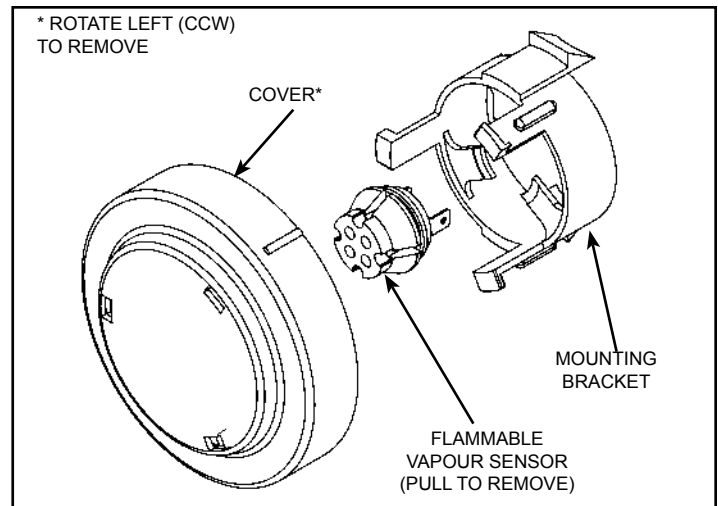

Figure 33

### Resettable Lockout

The gas control/thermostat can be reset by unplugging the power cord to remove power and then reinserting the plug to restore the power. Honeywell controls will automatically attempt to reset after a 20 minute wait period.

### Water Heater Operation

Figure 34 shows the water heater's sequence of operation when a call for heat is initiated. The ignition control module will attempt to light the burner three times. If the ignition control does not detect ignition it will enter lockout mode and flash the corresponding error code.

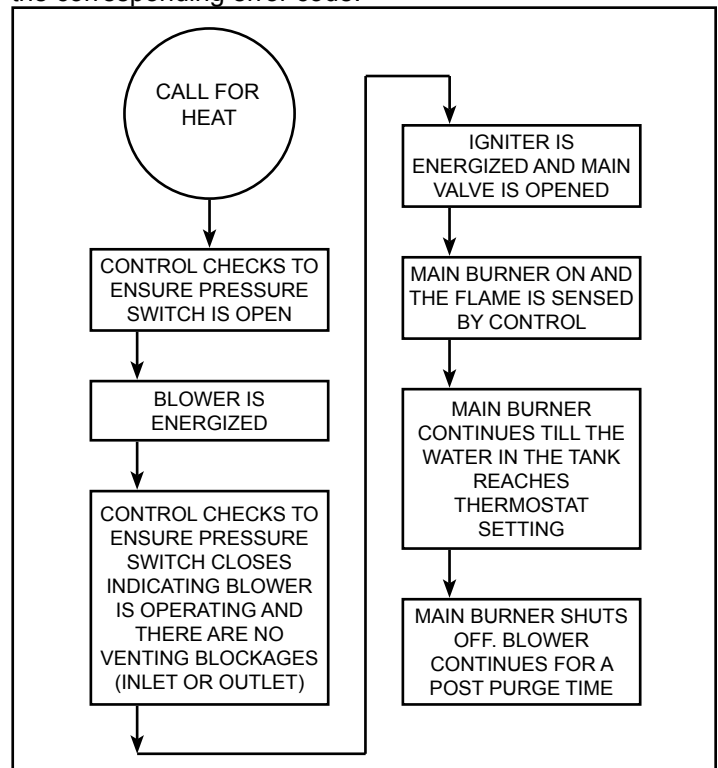

Figure 34

# Installation Checklist

**Note:** Use and complete this checklist before lighting the heater. Correct any conditions that do not meet these instructions.

Check Here

Check Here

## Water Heater Location

- 1. Centrally located with the water piping system. Located as close to gas piping and vent pipe system as possible.
- 2. Located indoors and in a vertical position. Protected from freezing temperatures.
- 3. Proper clearances from combustible surfaces maintained and not installed directly on a carpeted floor.
- 4. Provisions made to protect the area from water damage. Drain pan, if required, installed and piped to an adequate drain.
- 5. Installation area free of corrosive elements and flammable material.
- 6. Sufficient room to service the water heater.

## Gas Supply and Piping

- 1. Gas supply is the same type as listed on the water heater data plate.
- 2. Gas line equipped with shut-off valve, union and drip leg
- 3. Approved pipe joint compound used.
- 4. Adequate pipe size and of approved material.
- 5. Chloride-free soap and water solution or other approved means used to check all connections and fittings for possible gas leaks.

## Vent Pipe System

- 1. Vent pipe and fittings of approved material.
- 2. Acceptable size, length and number of elbows on exhaust vent system.
- 3. Installed in accordance with the latest edition of “**Natural Gas and Propane Installation Code**” **CSA-B149.1**.
- 4. Horizontal piping slopes at a pitch of 3mm (1/8 in.) rise per 1.2m (4 ft).
- 5. Not obstructed in any way.

## Vent Termination

### Horizontal

- 1. 300mm (12 in.) min. above grade or above anticipated snow level.
- 2. Away from corners, other vents, windows etc.

### Vertical

- 1. Exhaust vent termination 450mm (18 in.) min. above roof or above anticipated snow level.

## Water System Piping

- 1. Temperature and Pressure relief valve properly installed with a discharge line protected from freezing and run to an open drain.
- 2. All piping properly installed and free of leaks.
- 3. Heater completely filled with water.
- 4. Thermal expansion tank installed in closed system.

## Electrical Connections

- 1. Unit connected to an adequate 120V electrical supply.
- 2. Proper polarity.
- 3. Power supply properly grounded.
- 4. Installed in accordance with the latest edition of “**Canadian Electrical Code (CAN/CSA C22.1), Part I**”.

**After all actions on checklist are checked/completed, read the Lighting Instructions and proceed with lighting the heater.**

## OPERATING INSTRUCTIONS

### **⚠ CAUTION:**

**Read before proceeding. If you do not follow these instructions exactly, a fire or explosion may result, causing property damage, personal injury or loss of life.**

**This appliance is equipped with an ignition device that automatically lights the burner.**

**Do not try to light manually with a match or flame.**

### Temperature Regulation

This water heater's intended purpose is to heat water. Hot water is needed for cleaning and sanitizing (bodies, dishes, clothing etc.). Untempered hot water can present a scald hazard. Depending on the time element and the people involved (adults, children, elderly, infirm etc.) scalding may occur at different temperatures.

It is recommended that lower temperatures be used to avoid the risk of scalding. It is further recommended that the water temperature be set for the lowest temperature that will satisfy your hot-water needs. This will also provide the most energy efficient operation of the water heater.

Short, repeated heating cycles caused by small water uses can cause temperatures at the point-of-use to exceed the thermostat setting by up to 17°C (30°F). This condition is referred to as "stacking". If you experience this type of use you should consider using lower temperature settings to reduce scald hazards.

Valves for reducing the point-of-use temperature by mixing cold and hot water are available.

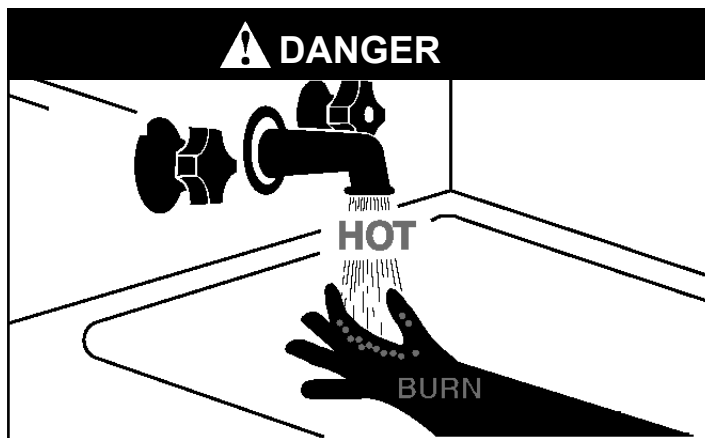

Water temperature over 52°C (125°F) can cause severe burns instantly or death from scalds.

Children, disabled and elderly are at highest risk of being scalded.

Feel water before bathing or showering.

Temperature limiting valves are available.

### Mixing Valves

**Hot water can scald:** Water heaters are intended to produce hot water. Water heated to a temperature that will satisfy space heating, clothes washing, dish washing, and other sanitizing needs can scald and permanently injure you upon contact. Some people are more likely to be permanently injured by hot water than others. These include the elderly, children, the infirm, and physically/mentally handicapped.

If any one using the hot water fits into one of these groups or if there is a provincial or local code requiring a certain temperature water at the hot water faucet, then you must take special precautions. In addition to using the lowest possible temperature setting that will satisfy your hot-water needs, a means such as a mixing valve, should be used at the hot-water faucets or at the water heater. Mixing valves are available at plumbing supply or hardware stores. Follow manufacturer's instructions for installation of these valves. Before changing the factory settings on the thermostat, read the "Temperature Regulation" section in this manual.

### **⚠ WARNING**

**Never allow small children to use a hot-water faucet, or to draw their own bath water. Never leave a child or impaired person unattended in a bathtub or shower. Scald burns can result.**

### **⚠ WARNING**

**Scald burns occur in under one second with 71°C (160°F) water, which the thermostat will deliver if the temperature is set at "VERY HOT". Lower settings of the temperature will reduce the risk of scald and will reduce your fuel bill.**

### **⚠ WARNING**

#### **Risk of scalding**

**Hot water can produce third degree burns**

**in 6 seconds at 60°C (140°F)**

**in 30 seconds at 54°C (130°F)**

**in 5 minutes at 49°C (120°F)**



## Lighting Instructions

Read and understand these directions thoroughly before attempting to operate the water heater. Make sure the viewport is not missing or damaged. Make sure the tank is completely filled with water before operating the water heater. The gas control valve/thermostat has an "On/Off Switch" and must be turned on before the water heater is operational. Check the label on the front of the water heater near the gas control valve/thermostat for the correct gas. Do not start this water heater with any gas other than the one listed on the label. If you have any questions or doubts, consult the gas supplier or gas utility company. The following Lighting Instruction label appears on the front of the water heater.

### FOR YOUR SAFETY READ BEFORE LIGHTING



**WARNING:** If you do not follow these instructions exactly, a fire or explosion may result causing property damage, personal injury or loss of life.



FLAMMABLE

**BEFORE OPERATING: ENTIRE SYSTEM MUST BE FILLED WITH WATER AND AIR PURGED FROM ALL LINES.**

A. This appliance does not have a pilot. It is equipped with an ignition device which automatically lights the burner. **Do NOT try to light the burner by hand.**



B. **BEFORE OPERATING** smell all around the appliance area for gas. Be sure to smell next to the floor because some gas is heavier than air and will settle on the floor.

**WHAT TO DO IF YOU SMELL GAS:**

- Do not try to light any appliance.
- Do not touch any electric switch; Do not use any phone in your building.
- Immediately call your gas supplier from a neighbor's phone. Follow the gas suppliers instructions.

- If you cannot reach your gas supplier, call the fire department.
- C. Use only your hand to turn the gas control buttons. Never use tools. If the control buttons will not turn, don't try to repair them, call a qualified service technician. Force or attempted repair may result in a fire or explosion.
- D. Do not use this appliance if any part has been under water. Immediately contact a qualified installer or service agency to replace a flooded water heater. Do not attempt to repair the unit. It must be replaced!

### OPERATING INSTRUCTIONS

1.  **STOP!** Read the safety information above on this label.
2. Turn off all electric power to the appliance.
3. Turn the thermostat counter-clockwise  to the lowest setting.
4. Set the switch on the control to the "OFF" position.
5. Do not attempt to light manually.
6. Wait five (5) minutes to clear out any gas. If you then smell gas, **STOP!**  Follow "B" in the safety information above on this label. If you don't smell gas, go the next step.

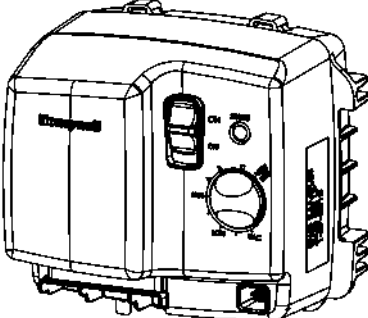

7. Turn on all electric power to the appliance.
8. Set the switch on the control to the "ON" position.
9. Turn thermostat to desired setting.

 **DANGER** Hotter water increases the risk of scald injury. Consult the instruction manual before changing temperature.

10. If the appliance will not operate, follow the instructions "To Turn Off Gas To Appliance" and call your service technician or gas supplier.

### TO TURN OFF GAS TO APPLIANCE

1. Turn the thermostat counter-clockwise  to the lowest setting.
2. Set the gas control switch to the "OFF" position.
3. Turn off electrical power to the appliance if service is to be performed.

324501-000

- 25 -

## Operating The Temperature Control System

It is recommended that lower water temperatures be used to avoid the risk of scalding. It is further recommended, in all cases, that the water temperature be set for the lowest temperature which satisfies your hot-water needs. This will also provide the most energy efficient operation of the water heater.

Short repeated heating cycles caused by small hot-water uses can cause a temperature increase of the hot water by 11C° (20F°) higher than the heater's temperature settings. If you experience this type of use you should consider using lower temperature settings to reduce scald hazards.

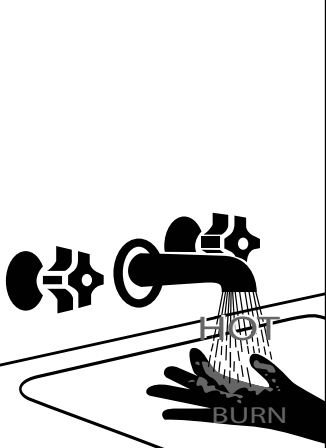

**⚠ DANGER** Water temperature over 125°F (52°C) can cause severe burns instantly resulting in severe injury or death.

Children, the elderly and the disabled and are at highest risk of scald injury.

Feel water before bathing or showering.

Temperature limiting devices such as mixing valves must be installed when required by codes and to ensure safe temperatures at fixtures.

Read instruction manual for safe temperature setting.

### HOT WATER CAN SCALD:

Water heaters are intended to produce hot water. Water heated to a temperature which will satisfy space heating, clothes washing, dish washing, and other sanitizing needs can scald and permanently injure you upon contact. Some people are more likely to be permanently injured by hot water than others. These include the elderly, children, the infirm, or physically/mentally handicapped. National plumbing code requirements limit the temperatures of certain fixtures in the home. Local codes may have additional requirements. If anyone using hot water from this heater fits into one of these groups or if there is a local code or state law requiring certain temperature water at the hot-water tap, then you must take special precautions. In addition to using the lowest possible temperature setting that satisfies your hot-water needs, a means such as a mixing valve, should be used at the hot-water taps used by these people or at the water heater. Mixing valves are available at plumbing supply or hardware stores (see Figure 11 & 12). Follow manufacturer's instructions for installation of the valves. Before changing the factory setting on the thermostat, in this manual, see Table 3.

The water heater should be located in an area where the general public does not have access. If a suitable area is not available, a cover should be installed over the thermostat to prevent tampering.

The water temperature setting was factory set at the lowest temperature.

This water heater is equipped with an adjustable thermostat to control water temperature. Hot water temperatures required for automatic dishwasher and laundry use can cause scald burns resulting in serious personal injury and/or death. The temperature at which injury occurs varies with the person's age and time of the exposure. The slower response time of children, aged or disabled persons increases the hazards to them. Never allow small children to use a hot-water tap, or to draw their own bath water. Never leave a child or disabled person unattended in a bathtub or shower.

Setting the water heater temperature at 49°C (120°F) will reduce the risk of scalds.

Should overheating occur or the gas supply fails to shut off, turn off the manual gas control valve/thermostat to the appliance.

### Gas Control Valve/Thermostat

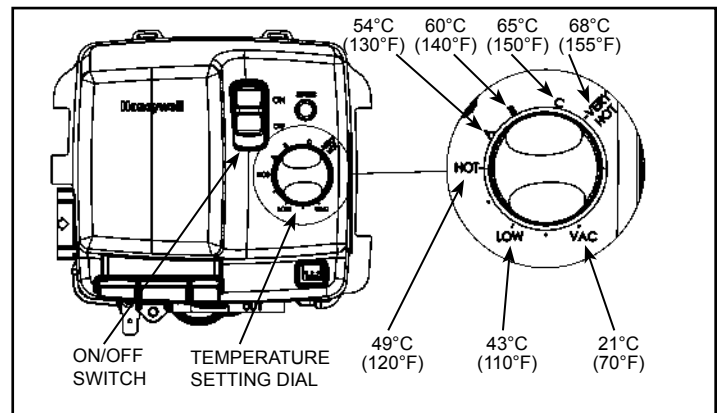

Figure 35

Temperature Dial Setting	Approximate Temperature °C (°F)	Time to induce a 2nd and 3rd Degree burn to adult skin
VERY HOT	68 (155)	Less than 1 second
C	65 (150)	Less than 3 seconds
B	60 (140)	About 5 seconds
A	54 (130)	About 30 seconds
HOT	49 (120)	More than 5 minutes
LOW	43 (110)	Normal shower temp
VAC	21 (70)	N/A

Table 3

**Note:** The temperatures indicated are approximate. The actual temperature of the heated water may vary.

The Vacation Setting (VAC) sets the controller at approximately 21°C (70°F). This setting is recommended when the water heater is not in use for a long period of time. This effectively turns the controller temperature setting down to a temperature that prevents the water in the water heater from freezing while still conserving energy.

## OPERATION

### Burner Flames

Inspect the burner flames through the viewport and compare them to the drawings in Figure 36. A properly operating burner should produce a soft blue flame. Blue tips with light blue inner cones are satisfactory. The tips of the flame may have a slight yellow tint. The flame should not be all yellow or have a sharp blue-orange colour. Contaminated air may cause an orange coloured flame. Contact a qualified service technician if the flame is not satisfactory.

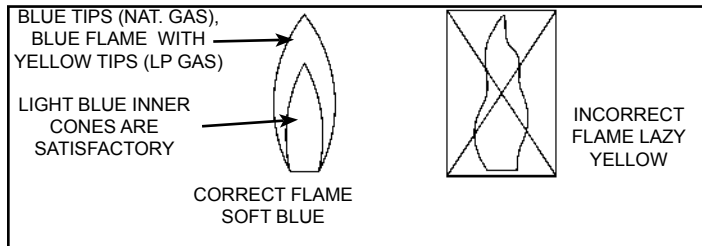

Figure 36

### Operational Conditions

#### Condensation

Moisture from the products of combustion condenses on the tank surface and forms drops of water that may fall onto the burner or other hot surfaces. This will produce a "sizzling" or "frying" noise. This condensation is normal and should not be confused with a leaking tank. Condensation may increase or decrease at different times of the year. High efficient energy saver water heaters will produce larger amounts of condensation on initial start-up or when a large amount of hot water is being used. Do not confuse this with a "tank leak". Once the water reaches operating temperature and the tank warms up (usually 1 hour), the condensation will stop.

Important: It is always recommended that a suitable drain pan be installed under the water heater to protect the area from water damage resulting from condensation, a leaking tank or piping connections. Refer to "Location Requirements". Under no circumstances is the manufacturer to be held responsible for any water damage in connection with this water heater.

#### Water Heater Sounds

During the normal operation of the water heater, sounds or noises may be heard. These noises are common and may result from the following:

1. Normal expansion and contraction of metal parts during periods of heat-up and cool-down.
2. Condensation causes sizzling and popping within the burner area and should be considered normal.
3. Sediment buildup in the tank bottom will create varying amounts of noise and may cause premature tank failure. Drain and flush the tank as directed under "Draining and Flushing".

#### Smoke/Odour

The water heater may give off a small amount of smoke and odour during the initial start-up of the unit. This is due to the burning off of oil from metal parts of a new unit and will disappear after a few minutes of operation.

#### Anode Rod/Water Odour

Each water heater contains at least one anode rod, which will slowly deplete while protecting the glass-lined tank from corrosion and prolonging the life of the water heater. Once the anode is depleted, the tank will start to corrode, eventually developing a leak. Certain water conditions will cause a reaction between this rod and the water. The most common complaint associated with the anode rod is a "rotten egg smell" produced from the presence of hydrogen sulfide gas dissolved in the water. **Do not remove this rod permanently as it will void any warranties, stated or implied.** A special anode can be ordered if water odour or discolouration occurs. **This rod may reduce, if not eliminate, water odour problems.** The water supply system may require special filtration equipment from water conditioning company to successfully eliminate all water odour problems.

#### "Air" In Hot-water Faucets

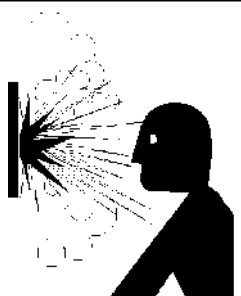
	<b>WARNING</b>
	<b>Explosion Hazard</b> <ul style="list-style-type: none"><li>• Flammable hydrogen gases may be present.</li><li>• Keep all ignition sources away from faucet when turning on hot water.</li></ul>

**HYDROGEN GAS:** Hydrogen gas can be produced in a hot-water system that has not been used for a long period of time (generally two weeks or more). Hydrogen gas is extremely flammable and explosive. To prevent the possibility of injury under these conditions, it is recommended that the hot-water faucet, located farthest away, be opened for several minutes before any electrical appliances which are connected to the hot-water system are used (such as a dishwasher or washing machine). If hydrogen gas is present, there will probably be an unusual sound similar to air escaping through the pipe as the hot-water faucet is opened. There must be no smoking or open flame near the faucet at the time it is open.

## MAINTENANCE

### Draining and Flushing

It is recommended that the user drain and flush the tank every 6 months to remove sediment that may build up during operation. The water heater should be drained if being shut down and exposed to freezing temperatures. To drain the tank, perform the following steps:

1. Turn off the gas to the water heater at the manual gas shut-off valve.
2. Turn off the electrical supply to the water heater.
3. Close the cold-water inlet valve.
4. Open a nearby hot-water faucet.
5. Connect a hose to the drain valve and terminate it to an adequate drain.

**Note:** The drain hose should be rated for at least 93°C (200°F). If the drain hose does not have this rating, open the cold-water inlet valve and a nearby hot-water faucet until the water is no longer hot.

6. Open the water heater drain valve and allow all the water to drain from the tank. Flush the tank with water as needed to remove sediment.
7. Close the drain valve, refill the tank, and restart the heater as directed under "Water Heater Operation".

If the water heater is going to be shut down for an extended period, the drain valve should be left open and the gas supply turned off.

Important: Condensation may occur when refilling the tank and should not be confused with a tank leak.

### Routine Preventative Maintenance (Homeowner/User)

**Important:** If you lack the necessary skills required to properly perform this visual inspection, you should not proceed, but get help from a qualified service technician.

At least annually, a visual inspection should be made of the venting and air supply system, piping systems and main burner. Check the water heater for the following:

- Build up of soot and carbon on the main burner. Check for a soft blue flame (see Figure 36).
- Leaking or damaged water and gas piping.
- Presence of flammable or corrosive materials in the installation area.
- Presence of combustible materials near the water heater.
- Verify proper operation after any service is performed on this water heater.

### Gas Control

There are no user serviceable parts in this control. The control is supplied with tamper resistant screws. DO NOT attempt to repair or adjust the control. If you experience problems, discontinue use and replace the control immediately. Continuing to use a damaged control could result in fire and/or explosion.

If you wish to verify that the water heater is operating properly:

1. Make sure there is power to the water heater.

2. Make sure that the gas is turned on to the water heater.
3. Initiate a call for heat by either drawing hot water from a nearby faucet or raising the temperature setting (see section "Temperature Regulation").
4. If an error code appears proceed to the "Troubleshooting" section.

### Temperature and Pressure Relief Valve

**WARNING**



**Explosion Hazard**

- **If the temperature and pressure relief valve is dripping or leaking, contact a qualified service technician.**
- **Do not plug valve.**
- **Do not remove valve.**
- **Failure to follow these instructions can result in death or an explosion.**

Manually operate the temperature and pressure relief valve periodically to make sure it is working properly (see Figure 37). To prevent water damage, the valve must be properly connected to a discharge line that terminates at an adequate drain. Standing clear of the outlet (discharged water may be hot), slowly lift and release the lever handle on the temperature and pressure relief valve to allow the valve to operate freely and return to its closed position. If the valve fails to completely reset and continues to release water, immediately shut off the manual gas valve and the cold-water inlet valve and call a qualified service technician.

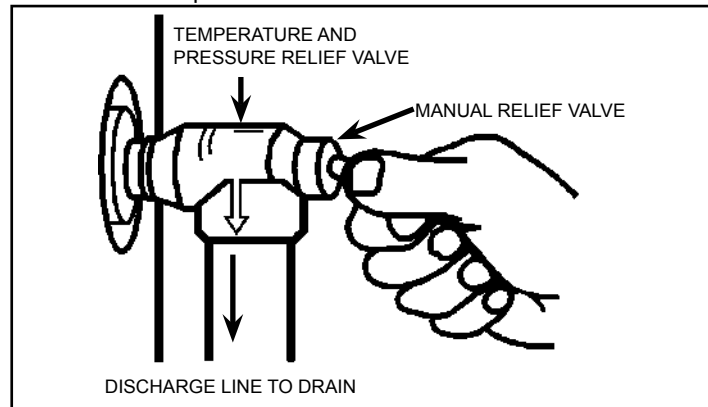

Figure 37

### Burner Operation and Inspection

At least once a year a visual inspection should be made of the main burner and the hot surface igniter assembly for proper flame characteristics and ignition sequences. This can be done by removing the outer door and viewing the main burner operation through the viewport on the inner door (see Figure 4). The main burner should provide complete combustion of gas, ignite rapidly, give reasonably quiet operation, and cause no excessive flame lifting from the burner ports. If the proper flame characteristics are not evident (see Figure 36),

make sure that the flow of combustion and ventilation air is not blocked.

You should also check for sooting. Soot is not normal and will impair proper combustion. A visual inspection of the main burner and hot surface igniter should also be done at least once a year (see Figure 38).

Soot build-up indicates a problem that requires correction before further use. Turn "OFF" gas to water heater by unplugging the power cord and leave off until repairs are made. Failure to correct the cause of the sooting can result in a fire causing death, serious injury, or property damage.

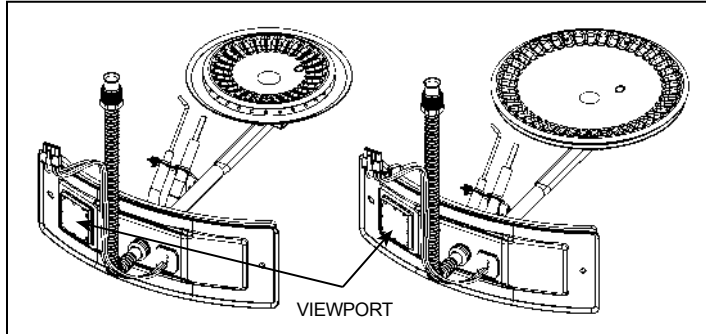



Figure 38

### Burner Cleaning

In the event your burner or burner air openings require cleaning, turn the gas control/thermostat switch to the "OFF" position and unplug the blower and allow the burner to cool. Call a service agency to remove and clean the burner and correct the problem that required the burner to be cleaned.

### Housekeeping

<b>⚠ DANGER</b>	
	<b>Fire and Explosion Hazard</b>
	<ul style="list-style-type: none"> <li>• Do not obstruct combustion air openings at the bottom of the water heater.</li> <li>• Do not use or store flammable vapor products such as gasoline, solvents or adhesives in the same room or area near water heater or other appliance.</li> <li>• Can cause serious injury or death.</li> </ul>

#### INSTALLED IN SUITABLE AREA:

To ensure sufficient ventilation and combustion air supply, proper clearances from the water heater must be maintained. See "Locating the New Water Heater" section. Combustible materials such as clothing, cleaning materials, or flammable liquids, etc. must not be placed against or adjacent to the water heater which can cause a fire.

### Anode Rod Inspection

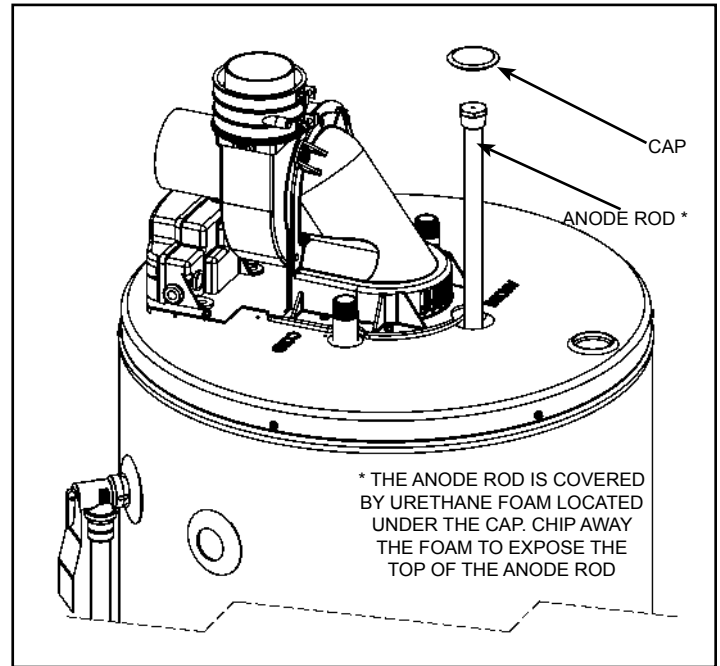

Figure 39

Each water heater contains at least one anode rod, which will slowly deplete (due to electrolysis) prolonging the life of the water heater by protecting the glass-lined tank from corrosion. Adverse water quality, hotter water temperatures, high hot water usage, hydronic heating devices, and water softening methods can increase the rate of anode rod depletion. Once the anode rod is depleted, the tank will start to corrode, eventually developing a leak.

Certain water conditions will cause a reaction between the anode rod and the water. The most common complaint associated with the anode rod is a "rotten egg smell" produced from the presence of hydrogen sulfide gas dissolved in the water.

**Important:** Do not remove this anode rod permanently as it will void any warranties. A special anode rod may be available if water odour or discolouration occurs.

**Note:** This anode rod may reduce but not eliminate water odour problems. The water supply system may require special filtration equipment from a water conditioning company to successfully eliminate all water odour problems.

Artificially softened water is exceedingly corrosive because the process substitutes sodium ions for magnesium and calcium ions. The use of excessively soft water may decrease the life of the water heater tank.

The anode rod should be inspected after a maximum of three years and annually thereafter until the condition of the anode rod dictates its replacement. The anode may need to be inspected more often in areas of hard water or highly conductive water. NOTE: Artificially softened water requires the anode rod to be inspected annually.

The following are typical (but not all) signs of a depleted anode rod (see Figure 40):

- The majority of the anode rod's diameter is less than 3/8".
- Significant sections of the support wire (approx. 1/3 or more of the anode rod's length) are visible.

If the anode rod show signs of either or both it should be replaced.

**Note:** Whether re-installing or replacing the anode rod, check for any leaks and immediately correct if found.

### To Remove the Anode Rod

1. Set the gas control valve/thermostat to its lowest setting by turning the knob counter-clockwise to the VAC point (Figure 35).
2. Turn gas control switch to the "OFF" position and turn "OFF" the gas supply to the unit (Figure 35).
3. Disconnect the electrical power to the water heater from the wall outlet.
4. Shut off the incoming water supply to the water heater and open a nearby hot-water faucet to depressurize the water tank.
5. Connect a hose to the drain valve and terminate it to adequate drain or to the exterior of the building. Open the drain valve and allow at least 5 gallons of water from the tank to drain. Close drain and remove hose.
6. Remove the anode cap on top of the heater and remove just enough insulation so you can access to the anode head (Figure 39). Keep in a safe place for reinstallation later.
7. Remove the anode rod by using a ratchet and a 1-1/16" socket turning counter-clockwise (Figure 39).

### To Install the Anode Rod

1. Use Teflon® tape or an approved pipe sealant on threads of the new anode rod.
2. Place the anode rod in the spud (top of the tank) and turn clockwise until the threads are hand tight. Using a ratchet and 1-1/16" socket tighten down water tight.
3. Open a nearby hot-water faucet to purge air from the water line. Fill water heater tank completely (Note: To assure the water heater tank is full, keep the hot-water faucet open for 3 minutes after a constant flow of water is obtained).
4. After turning off the hot-water faucet, check for water leaks around anode rod and immediately correct any if found.
5. Reinstall the insulation and anode cap which were removed in step 6 above.
6. Reconnect the electrical power to the water heater in the wall outlet and turn the gas supply back "ON" to the gas control valve/thermostat.
7. Turn the gas control switch to the "ON" position (Figure 35).
8. To restart the water heater, follow the directions on the "Lighting and Operating Instructions" label located on the front of the water heater near the gas control valve/thermostat.

See the "Repair Parts Illustration" for anode rod location.

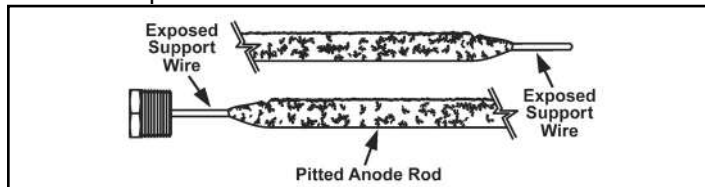

Figure 40

## Venting System and Blower



**WARNING**  
Keep the area around the heater clear and unobstructed.

Inspect the venting system periodically to make certain that the vent passageways, vent terminal and blower assembly are free and unobstructed. Ensure that any condensate is draining freely. Clean as necessary.

- Inspect the vent piping, elbows and connections for signs of stress cracking or deterioration. Make certain the venting is free to move and that all pipe hangers and isolation supports are properly positioned and securely attached. Any broken components or installation problems should be corrected by a qualified service technician.
- Particles, especially lint, can clog the vent blower wheel. This can be problematic, especially where condensation is present, as particles may adhere to the venting surfaces. These conditions can result in nuisance failures. In areas that have a high level of airborne particulate (e.g. lint, sawdust, process smoke, laundry areas, etc.) inspection and cleaning may need to be done more frequently. The blower wheel and venting must be cleaned as required to ensure proper performance. This must be done by a qualified service technician.
- Inspect the flue collector area for signs of corrosion (see Figure 41). This can be an indication of contaminated air, a wet environment, poor burner set up, or high levels of condensation occurring at the flue collector. Determine and correct any poor operating conditions.

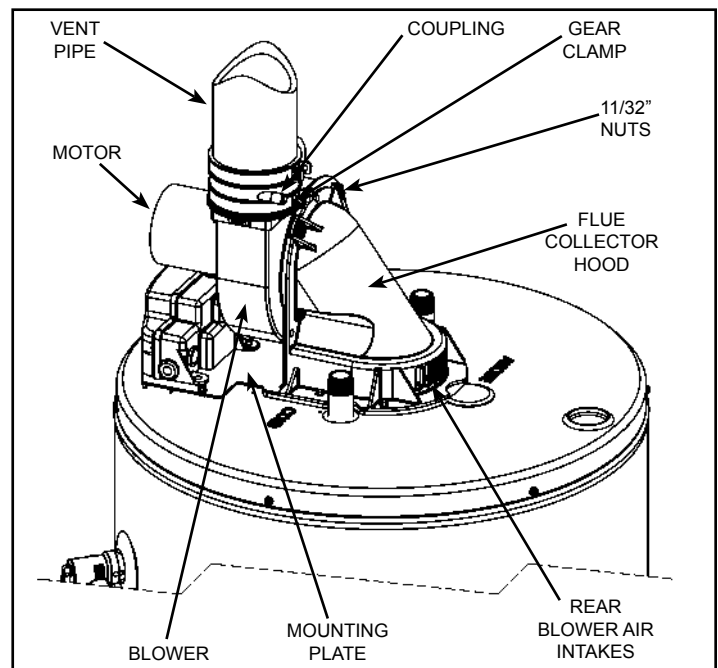

Figure 41

## COMBO HEATING

This section serves as a guide for the installation and use of "Combo" heating systems utilizing a domestic water heater that has been specifically approved for such use. It is written for those knowledgeable in the required trades and professionals involved in the design and installation of Combo Heating Systems.

It is the responsibility of the installer/designer to follow all applicable codes to ensure the effectiveness and safety of the installation.

### System Requirements

This water heater is suitable for combination water (potable) heating and space heating but not for space heating only.

The following requirements must be met for the installation of Combo Heating Systems:

1. All components used for the distribution of water in the heating loop must be suitable for potable water. These include all piping, fittings, solder and fluxes, pumps for circulation of water, valves, etc.
2. The water heater must not be connected to a hydronic heating system that has been used previously.
3. No boiler treatment chemicals of any kind shall be introduced into the system.
4. The Combo System components must be selected and sized to meet and maintain the total calculated demands for both domestic service hot water and space heating requirement. The sizing and installation must be performed in accordance with good engineering practice such as "ASHRAE Handbooks", HRAI's Unified Combo Guidelines, "Hydronics Institute Manuals", CSA-B149.1, ANSI Z223.1, CSA F280, National/ Provincial Building Codes, CSA C22.1, ANSI, CSA B51 and/or codes having jurisdiction.
5. The air handler (fan coil) and/or the circulating pump in a baseboard hydronic loop will require a dedicated 120V circuit. This must be provided and identified for this purpose.
6. All piping between the water heater and the air handler or hydronic baseboard loop must be adequately insulated to reduce heat loss.
7. If the local jurisdiction requires a back-flow preventer in the cold water line, an expansion tank of adequate size must be installed.
8. "Combo" Heating Systems require higher water temperatures than other applications. When the system is used to supply water for Combo Heating applications, a means, such as mixing valve, must be installed to temper the water in order to reduce scald hazard potential (see Figures 42 & 43).

### Installation

The heating mode may be one of the following options:

- A. A fan coil/air handler (Figure 42).
- B. A hydronic baseboard (finned tube) loop/In floor heating (Figure 43).

The following is a list of requirements for the installation of option A or B.

1. Install shut-off valves and unions so that the water heater

can be isolated from the heating module should servicing of the water heater become necessary.

2. Install a drain valve at the lowest point of the heating loop so that water can be drained from the heating module without affecting the water heater.
3. If the air handler does not have a venting means at the highest point of the piping arrangement, install an air bleed at the highest point of the plumbing arrangement.
4. A properly-sized thermal expansion tank should be installed on all closed systems to control the harmful effects of thermal expansion. Contact a plumbing service agency or your retail supplier regarding the installation of a thermal expansion tank.

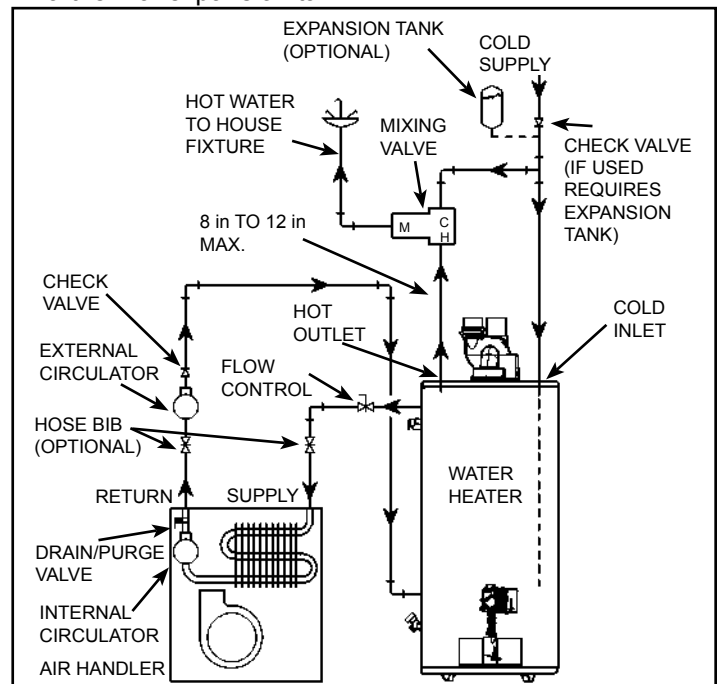

Figure 42

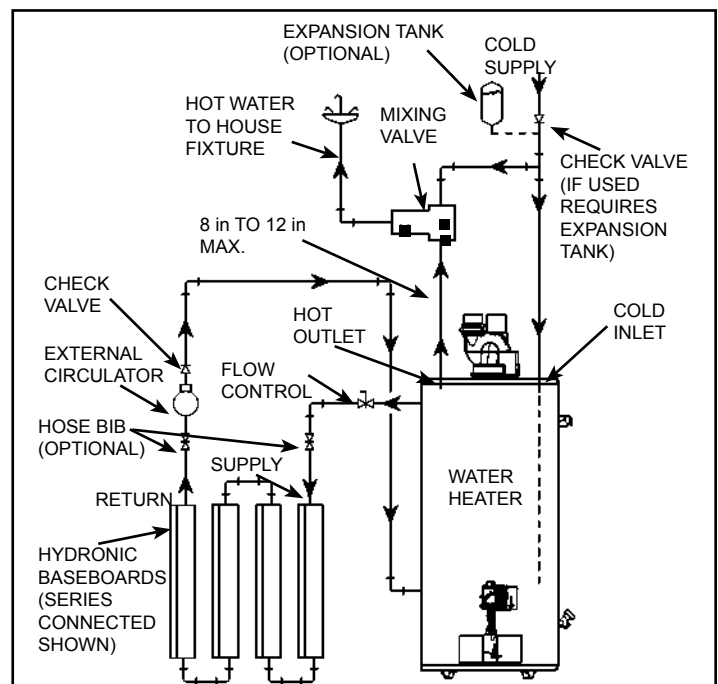

Figure 43

## TROUBLESHOOTING GUIDE

These guidelines should be utilized by a qualified service agent.

PROBLEM	POSSIBLE CAUSE(S)	CORRECTIVE ACTION
BURNER FLAME TOO HIGH	<ol style="list-style-type: none"> <li>1. Air inlets blocked</li> <li>2. Insufficient secondary air</li> <li>3. Orifice too large</li> </ol>	<ol style="list-style-type: none"> <li>1. Unblock inlet air openings</li> <li>2. Provide ventilation to water heater</li> <li>3. Replace with correct orifice</li> </ol>
FLAME BURNS AT ORIFICE	<ol style="list-style-type: none"> <li>1. Low gas pressure</li> <li>2. Defective gas control valve/thermostat</li> </ol>	<ol style="list-style-type: none"> <li>1. Check with gas utility company</li> <li>2. Replace gas control valve/thermostat</li> </ol>
INSUFFICIENT HOT WATER	<ol style="list-style-type: none"> <li>1. Low gas pressure</li> <li>2. Orifice too small</li> <li>3. Thermostat set too low</li> <li>4. Gas control error codes</li> <li>5. Sediment or lime in tank</li> <li>6. Water heater too small</li> <li>7. Wrong piping connections</li> <li>8. Leaking faucets</li> <li>9. Wasted hot water</li> <li>10. Long runs of exposed piping</li> <li>11. Hot-water piping in outside wall</li> </ol>	<ol style="list-style-type: none"> <li>1. Check with gas utility company</li> <li>2. Replace with correct orifice</li> <li>3. Turn temperature knob to higher setting</li> <li>4. Refer to gas control error codes</li> <li>5. Drain/flush-provide water treatment if needed</li> <li>6. Install adequate heater</li> <li>7. Correct piping: dip tube must be in cold inlet</li> <li>8. Repair faucets</li> <li>9. Advise customer</li> <li>10. Insulate piping</li> <li>11. Insulate piping</li> </ol>
WATER IS TOO HOT	<ol style="list-style-type: none"> <li>1. Thermostat is too high</li> <li>2. Defective gas control valve/thermostat</li> </ol>	<ol style="list-style-type: none"> <li>1. Turn temperature knob to lower setting</li> <li>2. Replace the gas control valve/thermostat</li> </ol>
SLOW HOT WATER RECOVERY	<ol style="list-style-type: none"> <li>1. Insufficient secondary air</li> <li>2. Low gas pressure</li> <li>3. Orifice too small</li> <li>4. Thermostat set too low</li> <li>5. Heater too small</li> <li>6. Wrong piping connection</li> <li>7. Wasted hot water</li> <li>8. Flue clogged</li> <li>9. Air inlets blocked</li> </ol>	<ol style="list-style-type: none"> <li>1. Provide ventilation to water heater. Check flue way, flue baffle and burner</li> <li>2. Check with gas utility company</li> <li>3. Replace with correct orifice</li> <li>4. Turn temperature knob to higher setting</li> <li>5. Install adequate heater</li> <li>6. Correct piping-dip tube must be in cold inlet</li> <li>7. Advise customer</li> <li>8. Clean flue, locate source and correct</li> <li>9. Unblock inlet air openings</li> </ol>
DRIP FROM RELIEF VALVE	<ol style="list-style-type: none"> <li>1. Pressure build-up</li> <li>2. Heater stacking</li> <li>3. Closed water system</li> <li>4. Improperly seated valve</li> </ol>	<ol style="list-style-type: none"> <li>1. Use a pressure-reducing valve and relief valve</li> <li>2. Lower the thermostat setting</li> <li>3. See thermal expansion section</li> <li>4. Check Relief valve for proper operation (Do Not plug T&amp;P valve)</li> </ol>
GAS CONTROL VALVE/ THERMOSTAT FAILS TO SHUT OFF	<ol style="list-style-type: none"> <li>1. Defective gas control valve/thermostat</li> </ol>	<ol style="list-style-type: none"> <li>1. Replace gas control valve/thermostat</li> </ol>
SMELLY WATER	<ol style="list-style-type: none"> <li>1. Sulfides in water supply</li> <li>2. Bacteria in water supply</li> <li>3. Standard anode incompatible with water composition</li> </ol>	<ol style="list-style-type: none"> <li>1. Chlorination procedure</li> <li>2. Chlorination procedure</li> <li>3. Install special anode</li> </ol>
CONDENSATION	<ol style="list-style-type: none"> <li>1. Filling the new water heater for the first time</li> <li>2. Moisture from the products of combustion</li> <li>3. Water dripping from blower assembly</li> <li>4. Undersized water heater</li> </ol>	<ol style="list-style-type: none"> <li>1. Normal operation: the condensation should disappear after heater warms up</li> <li>2. Normal operation: the condensation should disappear in time</li> <li>3. Install condensate hose to drain port on the rubber coupling</li> <li>4. Install adequate heater</li> </ol>



<b>PROBLEM</b>	<b>POSSIBLE CAUSE(S)</b>	<b>CORRECTIVE ACTION</b>
COMBUSTION ODOURS	<ol style="list-style-type: none"> <li>1. Air inlets blocked</li> <li>2. Insufficient secondary air</li> <li>3. Flue clogged</li> <li>4. Heater installed in a confined area</li> <li>5. House too tight</li> </ol>	<ol style="list-style-type: none"> <li>1. Unblock inlet air openings</li> <li>2. Provide fresh air ventilation to the water heater</li> <li>3. Clean, locate source and correct</li> <li>4. Provide fresh air ventilation to the water heater</li> <li>5. Provide fresh air ventilation to the water heater</li> </ol>
SMOKING AND CARBON FORMATION	<ol style="list-style-type: none"> <li>1. Air inlets blocked</li> <li>2. Insufficient secondary air</li> <li>3. Low gas pressure</li> <li>4. Orifice too large</li> <li>5. Flue clogged</li> <li>6. Defective gas control valve/thermostat</li> <li>7. Heater installed in a confined area</li> </ol>	<ol style="list-style-type: none"> <li>1. Unblock inlet air openings</li> <li>2. Provide ventilation to water heater. Check flue way, flue baffle and burner</li> <li>3. Check with gas utility company</li> <li>4. Replace with correct orifice</li> <li>5. Clean, locate source and correct</li> <li>6. Replace gas control valve/thermostat</li> <li>7. Provide fresh air ventilation</li> </ol>
UNABLE TO LIGHT THE BURNER	<ol style="list-style-type: none"> <li>1. Air in gas line</li> <li>2. Pressure switch</li> <li>3. Blocked exhaust</li> <li>4. Wire connection</li> <li>5. Defective gas control valve/thermostat</li> <li>6. Defective igniter</li> </ol>	<ol style="list-style-type: none"> <li>1. Purge the air from gas line</li> <li>2. Check the pressure switch, make sure the pressure switch hose is not kinked</li> <li>3. Check vent pipe for blockage</li> <li>4. Check wire connections</li> <li>5. Replace the gas control valve/thermostat</li> <li>6. Replace igniter</li> </ol>
SIZZLING, RUMBLING NOISE	<ol style="list-style-type: none"> <li>1. Scale and sediment</li> <li>2. Condensation dripping on burner</li> </ol>	<ol style="list-style-type: none"> <li>1. Drain/flush-provide water treatment if needed</li> <li>2. Refer to "Condensate" section</li> </ol>
WATER LEAKAGE	<ol style="list-style-type: none"> <li>1. Condensation</li> <li>2. Dripping Temperature &amp; Pressure Relief Valve</li> <li>3. Thermostat does not shut-off</li> <li>4. Drain valve dripping/leaking</li> <li>5. Tank Leak</li> </ol>	<ol style="list-style-type: none"> <li>1. Refer to "Condensate" section</li> <li>2. Refer to "Temperature &amp; Pressure Relief Valve" section</li> <li>3. Check the Thermostat</li> <li>4. Back flush to clean- out sediment, replace if necessary.</li> <li>5. Check "Leakage Checkpoints"</li> </ol>
BLOWER WILL NOT START	<ol style="list-style-type: none"> <li>1. No power to unit</li> <li>2. Thermostat set too low</li> <li>3. Defective air pressure switch</li> <li>4. Defective blower</li> <li>5. Disconnected or loose wire</li> <li>6. Control locked out</li> <li>7. Incorrect polarity</li> </ol>	<ol style="list-style-type: none"> <li>1. Plug in power cord, check fuses and/or supply voltage</li> <li>2. Turn temperature knob to higher setting</li> <li>3. Replace air pressure switch</li> <li>4. Replace blower</li> <li>5. Repair and reconnect wires</li> <li>6. Reset – determine cause of lockout</li> <li>7. Repair polarity</li> </ol>
BLOWER RUNS CONTINUOUSLY	<ol style="list-style-type: none"> <li>1. Air pressure switch not closing due to insufficient draft – check for: <ol style="list-style-type: none"> <li>a. Vent piping blocked</li> <li>b. Piping length too long</li> <li>c. Clogged/dirty blower</li> </ol> </li> <li>2. Disconnected, torn or blocked pressure switch hose from air pressure switch to blower housing</li> <li>3. Defective pressure switch</li> <li>4. High limit switch open due to excessive vent temperature or defective switch</li> </ol>	<ol style="list-style-type: none"> <li>1. Determine cause of insufficient draft. Check draft with manometer at pressure switch <ol style="list-style-type: none"> <li>a. Remove blockage</li> <li>b. Reduce vent length/increase vent size</li> <li>c. Clean blower wheel</li> </ol> </li> <li>2. Reconnect or replace pressure switch hose</li> <li>3. Replace defective pressure switch</li> <li>4. Determine cause of overheating check for: overfiring, insufficient air supply, high ambient air temperature (once high limit switch activated, must be replaced)</li> </ol>

PROBLEM	POSSIBLE CAUSE(S)	CORRECTIVE ACTION
HOT SURFACE IGNITER NOT GLOWING FOLLOWING WARM-UP PERIOD	<ol style="list-style-type: none"> <li>120VAC polarity reversed at 120VAC outlet receptacle</li> <li>Defective hot surface igniter</li> <li>Defective gas control valve/thermostat</li> </ol>	<ol style="list-style-type: none"> <li>Reverse polarity at 120VAC outlet receptacle</li> <li>Replace igniter</li> <li>Replace gas control valve/thermostat</li> </ol>
VENT PIPE TOO HOT (ABOVE 149°F)	<ol style="list-style-type: none"> <li>Blower does not run when heater fired</li> <li>Not enough dilution air to mix with flue gases</li> <li>Air in room too hot for mixing with flue gases</li> <li>Wrong burner orifice</li> <li>Baffle incorrect or missing</li> </ol>	<ol style="list-style-type: none"> <li>Refer to "BLOWER WILL NOT START" problem</li> <li>Proper air circulation must be provided for combustion and dilution of flue temp</li> <li>Room air to be used for dilution with combustion products in flue should be less than 90°F</li> <li>Install correct orifice.</li> <li>Contact water heater supplier</li> </ol>

### Ignition State and Timing

IGNITION STATE	TIMING
Pre-purge	5 seconds (NG models)
	15 seconds (LP models)
HSI Warmup	10 seconds
Ignition Activation Period (IAP)	3.5 seconds maximum
Flame Recognition Period (FRP)	0.5 second
Trial For Ignition	IAP + FRP
Flame Stabilization Period	Not Applicable
Inter-purge	30 seconds
Flame Failure Response Time	2 seconds max (@ 1uA flame current)
Post-purge	30 seconds
PS Prove Period	2 minutes
PS Fault Delay (failed open/closed)	2 minutes
Soft Lockout	20 minutes
ECO Limit Lockout	Indefinite
Flammable Vapour Sensor Lockout	Indefinite (follow defined procedure to restart)
Hardware Fault Lockout	Indefinite (clear fault to restart in 15 seconds or less)

## System Error Codes

The micro-controller inside the gas control monitors the flammable vapour safety features, the ignition sequence, temperature settings and overall operation of the heater. If any of these parameters does not operate properly the controller will shut down the water heater, diagnose the failure and flash an error code. Table 2 lists the System Status Codes for the Honeywell control. Refer to Table 2 and to the “Trouble Shooting Guide” to diagnose the problem before attempting corrective action. See also “Flammable Vapour Sensor” and “Resettable Lockout”.

### Honeywell Troubleshooting Chart - User Control

LED Flash Sequence	Control Status
Short flash once every four seconds	IDLE (no call for heat, no fault conditions)
“Heartbeat”, alternates bright/dim	Call For Heat (no fault conditions)
One Flash, three second pause	Low Flame Signal (control continues to operate)
Two Flash, three second pause	Pressure Switch Failed Closed
Three Flash, three second pause	Pressure Switch Failed Open
Four Flash, three second pause	ECO Limit Lockout thermostat temperature limit was exceeded.
Five Flash, three second pause	Flame Out Of Sequence
Six-One Flash, three second pause	Soft Lockout – Retry Limit - Failed TFI
Six-Two Flash, three second pause	Soft Lockout - Recycle Limit - PS/Limit opened
Six-Three Flash, three second pause	Soft Lockout - Recycle Limit - Flame Lost
Six-Four Flash, three second pause	Soft Lockout - Flame out of Sequence Sensed
Seven Flash, three second pause	Flammable Vapour Sensor Lockout
Eight-One Flash, three second pause	FVS Fault Detected
Eight-Two Flash, three second pause	Temperature Sensor Fault Detected
Eight-Three Flash, three second pause	Electronics Fault Detected
Eight-Four Flash, three second pause	Valve Fault Detected

**Table 2**

## REFERENCE PARTS

### Reference Parts Listing

Replacement parts may be ordered through your plumber or the local distributor. When ordering replacement parts, always have the following information ready:

1. Model, Serial and Catalogue (SKU) number
2. Type of gas
3. Item number
4. Parts description

1. Vent Termination Elbow with Rodent Screen
2. \*\*Vent Pipe
3. \*\*Vent Pipe Coupling (if required)
4. \*\*Vent Pipe Elbow (long radius)
5. Limit Switch (see Figure 49)
6. T&P Valve
7. Diptube
8. Baffle Assembly
9. \*\* Discharge Pipe
10. Gas Control Valve/Thermostat (Honeywell)

11. Gas Valve Electronic Control Module And Cover (Honeywell)
12. Drain Valve
13. Outer Gas Door
14. Manifold Door Assembly (behind outer door) (see Figures 46 & 47)
15. \*\*Floor Drain
16. \*\*Metal Drain Pan
17. Flammable Vapour Sensor (under cover) (see Figure 48)
18. Combo Heating System Return Inlet (Optional)
19. Air Inlet Snorkel
20. Combo Heating System Supply Outlet (Optional)
21. Blower with Power Cord (see Figure 49)
22. Air Switch (inside box) (see Figure 49)
23. Junction Box (see Figure 49)
24. Junction Box Cover (see Figure 49)
25. Air Tubing (see Figure 49)

26. Rubber Coupling
27. Gear Clamp
28. Flue Collector
29. Hot-Water Outlet Nipple
30. Anode (under cap)
31. Cold-Water Inlet Nipple
32. Flexible Manifold Tube (see Figures 46 & 47)
33. Viewport (see Figures 46 & 47)
34. Flame Sensor Rod (see Figures 46 & 47)
35. Gas Orifice (see Figures 46 & 47)
36. Sheet Metal Burner (see Figures 46 & 47)
37. Gas Manifold (see Figures 46 & 47)
38. Hot-Surface Igniter (see Figures 46 & 47)
39. Manifold Door Gasket (see Figures 46 & 47)
40. Manifold Door (see Figures 46 & 47)
41. Two Piece Grommet With Clip (see Figures 46 & 47)

\*\* parts not supplied with the water heater

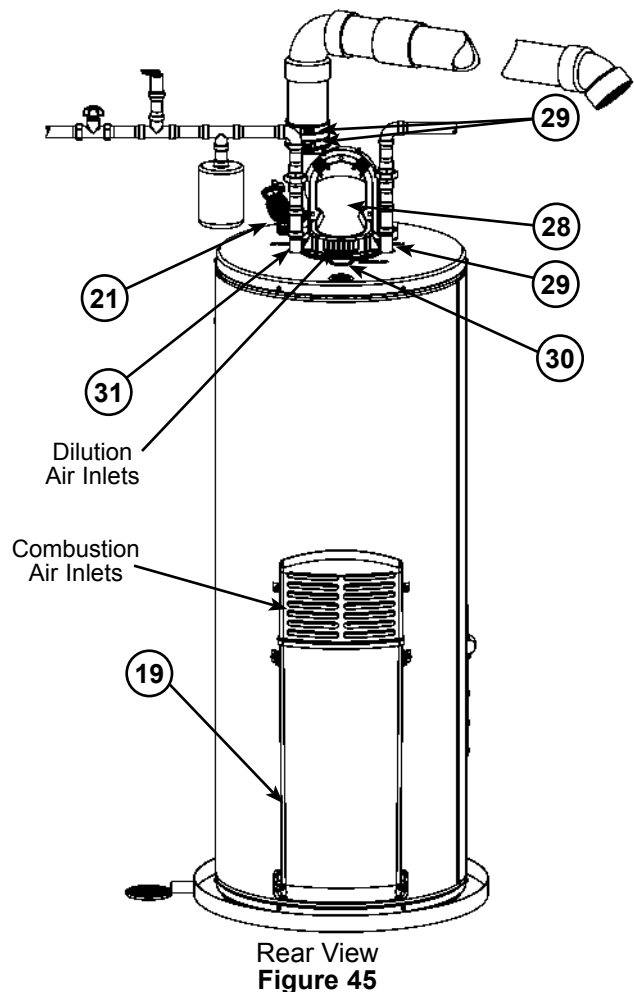
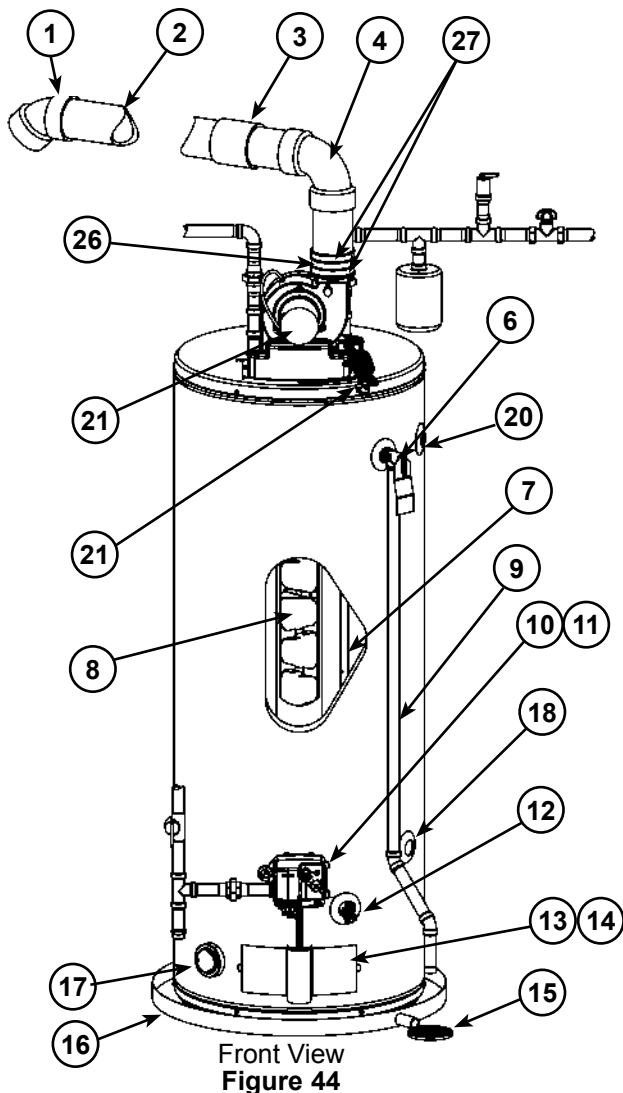

Natural gas and Propane main burner with igniter assembly for 40k to 50k Btu/hr models

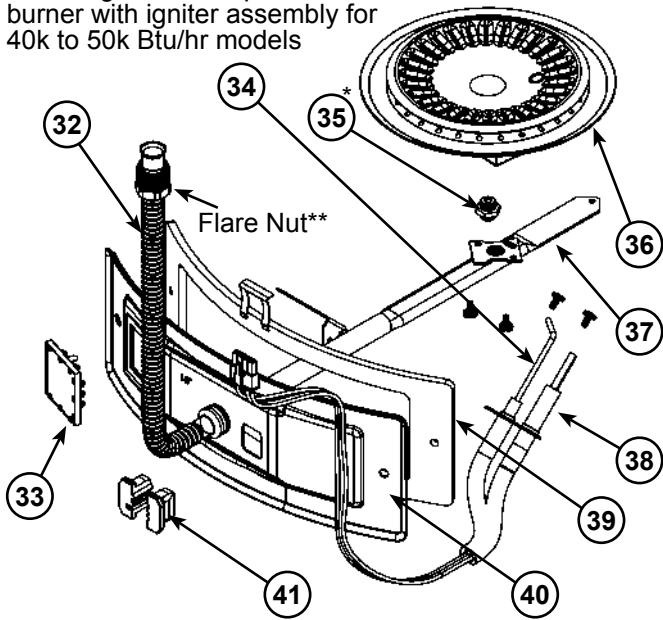

Figure 46

Natural gas and Propane main burner with igniter assembly for 60k to 75k Btu/hr models

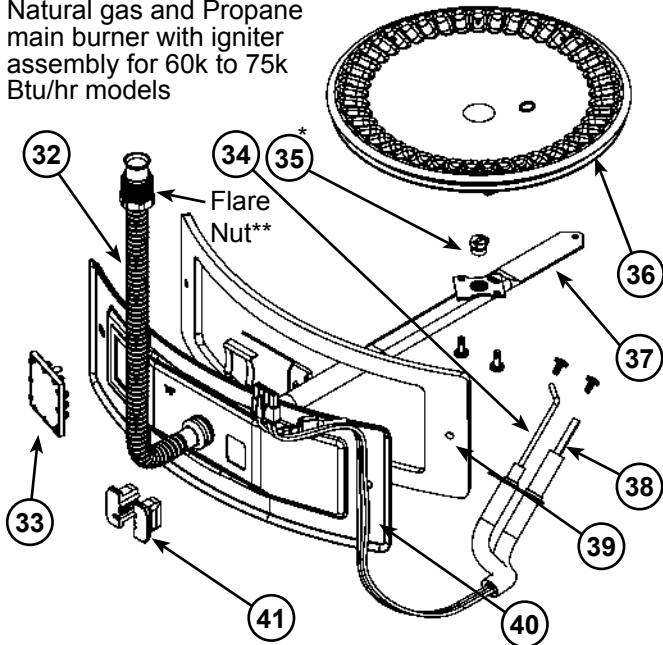

Figure 47

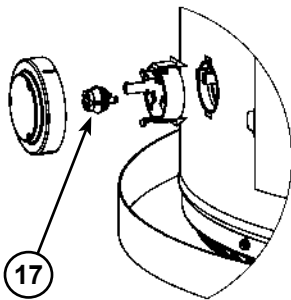

Figure 48

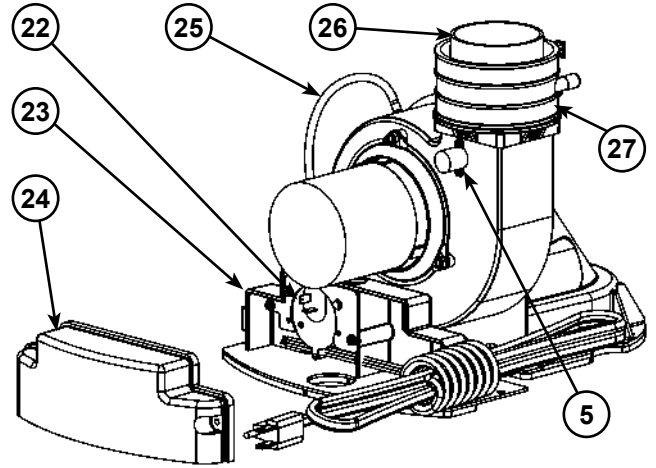
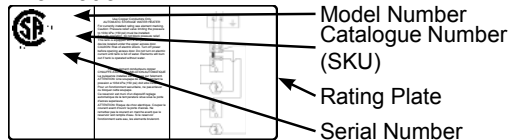

Figure 49

Notes: \* Natural gas models have Right-hand thread, Propane models have Left-hand thread.

\*\* For Natural gas models the Flare Nut has Right-hand thread. For Propane models the Flare Nut has Left-hand thread.

When referencing the water heater for service or warranty, please refer to the rating plate affixed to the unit for the following information:



Warranty Code:	P	R	S	U	V	W	Y
Inner Tank Warranty Years:	3	5	6	8	9	10	12
Component Part Warranty Years:	1	1	1	6	1	1	1

The Serial Number contains the warranty and manufacture date information for the unit as follows:

U9999 F999999  
 Warranty code  
 Year of manufacture  
 Week of manufacture

Example: U1005 F001234  
 Manufactured in week 5  
 Manufactured in 2010  
 8 year tank, 6 year parts warranty

The Warranty Code indicates the inner tank and component part warranties as shown in the table above.

**LIMITED WARRANTY**

**RESIDENTIAL STORAGE TANK TYPE WATER HEATER FOR INSTALLATION IN A SINGLE FAMILY DWELLING**

**A. WHO IS COVERED.**

GSW WATER HEATING AND ITS SUPPLIERS, (herein collectively referred to as “Manufacturer”) warrants only to the original consumer purchaser (hereinafter “Owner”) of the water heater, within the boundaries of the continental United States or Canada, or their territories, so long as he or she continuously occupies the single family dwelling in which this water heater is initially installed for the period specified below. This Warranty is not transferable. This Warranty is reduced to one year if the water heater is used in a commercial or industrial application, or if the water heater is used to supply more than one dwelling unit. Consumers must retain point-of-sale proof of purchase to validate warranty entitlement.

**B. WHEN IT IS COVERED.**

The water heater is warranted only when it is installed, operated, and maintained in accordance with the printed instructions accompanying the water heater. The water heater shall/must be installed in such a manner that, if the tank or any connection thereto should leak, the resulting flow of water will not cause damage to the area in which it is installed. The water heater’s temperature and pressure relief valve must be piped to the nearest drain to avoid damage in the event the valve is actuated. For detailed instructions, read the manual accompanying the water heater and review drawings in the manual.

**C. WHAT THE MANUFACTURER WILL DO AND THE PERIOD OF COVERAGE.**

1. **The Inner Tank.** If the inner tank leaks within the warranty period shown in the table above after the original installation, the Manufacturer will furnish a new water heater of the Manufacturer’s then prevailing comparable model. If industry standards, regulatory changes, product improvements, or product obsolescence prohibits the Manufacturer from furnishing an identical model replacement water heater under this Warranty, the Owner will be furnished with a new water heater of comparable capacity; however, the Owner will be charged for the additional value of the item(s) which the Manufacturer has incorporated in the replacement water heater. A prior authorization number must be obtained from the Manufacturer before replacing the water heater. This Warranty is limited to one replacement water heater at the original installation site.
2. **Component Part.** If any component, part other than the inner tank, proves to the Manufacturer’s satisfaction to be defective in material or workmanship within the warranty period shown in the table above after the original installation, the Manufacturer will furnish the Owner with a replacement for the defective part(s). This Warranty is limited to one replacement component part for each original part.
3. **Return of Defective Water Heater and Component Parts.** The Manufacturer reserves the right to examine the alleged defect in the water heater or component part(s). As such, it will be the Owner’s obligation (see paragraph D. 3) to return the water heater and/or component part(s) to the Manufacturer.
  - a. When returning a water heater, it must include all component parts and the rating plate label.
  - b. When returning component part(s), they must be individually tagged and identified with the water heater’s Model Number, SKU, Serial Number, date of purchase, and date of installation.
  - c. THERE ARE NO WARRANTIES WHICH EXTEND BEYOND THE DESCRIPTION ON THE FACE HEREOF. THIS EXPRESS WARRANTY IS, WHERE PERMITTED BY LAW, IN LIEU OF AND EXCLUDES AND REPLACES ALL OTHER CONDITIONS, WARRANTIES, GUARANTEES, REPRESENTATIONS, OBLIGATIONS OR LIABILITIES OF THE MANUFACTURER OF ANY NATURE OR KIND, EXPRESS OR IMPLIED, HOWEVER ARISING (WHETHER BY CONTRACT, CONDUCT, STATEMENT, STATUTE, NEGLIGENCE, PRINCIPLES OF MANUFACTURER’S LIABILITY, OPERATION OF LAW, OR OTHERWISE) WITH RESPECT TO THE UNIT OR ITS FITNESS FOR A PARTICULAR PURPOSE, MERCHANTABILITY, INSTALLATION, OPERATION, REPAIR, OR REPLACEMENT. THE MANUFACTURER EXPRESSLY DISCLAIMS ANY AND ALL IMPLIED WARRANTIES. IN NO EVENT WILL THE MANUFACTURER’S LIABILITIES EXCEED THE COST OF THE DEFECTIVE PART(S) OR UNIT.

**D. WHAT THIS WARRANTY DOES NOT COVER.**

1. The Unit must not be installed where water damage can result from a leak, while provision(s) shall be made for directing any water escaping from the Unit to a properly operating drainpipe. As all units of this type may eventually leak, you must protect against any potential water damage. The Manufacturer accepts no responsibility for such damage, nor any incidental or consequential loss, nor damage(s) related thereto, suffered by the Owner of the Unit nor by any third party.
2. The Manufacturer shall not be liable under this Warranty and this Warranty shall be void and have no effect if the following events occur:
  - a. The water heater or any of its component parts have been subject to misuse, alteration, neglect, or accident; or

- b. The water heater has not been installed in accordance with the applicable local plumbing and/or building code(s) and/or regulations or, in their absence, with the latest edition of the Natural Gas and Propane Installation Code, and/or the Canadian Electrical Code; or
  - c. The water heater is not installed, operated, and maintained in accordance with the Manufacturer's instructions, including if the water heater has any additional aftermarket equipment introduced into the sealed system not approved by the Manufacturer; or
  - d. The water heater or any of its component parts are damaged or fails from operation with an empty or partially empty tank (such as, but not limited to elements burned out in a dry tank); or
  - e. The water heater or any part has been under water; or
  - f. The water heater is exposed to highly corrosive atmospheric conditions. No warranty extends, for example, and without limitation of the foregoing, to Units exposed to: salts, chemicals, exhausts, pollutants, or contaminants; or
  - g. The water heater is not continuously supplied with potable water; or
  - h. The water heater replacement is requested for reasons of noise, taste, odour, discolouration, and/or rust; or
  - i. The water heater is operated at temperatures exceeding the maximum setting of the thermostat and/or high limit control provided by the Manufacturer, or at water pressures exceeding the pressure reading stated on the Unit; or
  - j. The water heater is operated without an operating anode; or
  - k. The water heater is supplied or operated with deionized water; or
  - l. The water heater is removed from its original installation location; or
  - m. The water heater is installed outdoors (this water heater is intended only for indoor installation); or
  - n. The water heater is converted, or is attempted to be converted, from one voltage or wattage to another, if an electric water heater, or from one gas type to another, if a gas water heater; or
  - o. The water heater has not been fired at the factory rated input and fuel for which it was factory built; or
  - p. The water heater or any of its component parts fail due to sediment build-up; or
  - q. The water heater does not have installed a properly operating temperature and pressure relief valve, certified to ANSI Z21.22/CSA "Requirements for Relief Valves for Hot Water Supply Systems"; or
  - r. The water heater or any of its component parts fail because of fire, floods, lightning, or any other act of God, or any other contingency beyond the control of the Manufacturer; or
  - s. The water heater is installed in a closed system without adequate provision for thermal expansion.
3. Except when specifically prohibited by the applicable law, the Owner, and not the Manufacturer, shall be liable for and shall pay for all charges for labour or other expenses incurred in the removal, repair, or replacement of the water heater or any component part(s) claimed to be defective or any expense incurred to remedy any defect in the product. Such charges may include, but are not necessarily limited to:
- a. All freight, shipping, handling, and delivery costs of forwarding a new water heater or replacement part(s) to the Owner.
  - b. All costs necessary or incidental in removing the defective water heater or component part(s) and installing a new water heater or component part(s).
  - c. Any material required to complete and/or permits required for the installation of a new water heater or replacement part(s), and
  - d. All costs necessary or incidental in returning the defective water heater or component part(s) to a location designated by the Manufacturer.
4. The terms of this Limited Warranty cannot be modified by any person, whether or not he/she claims to represent or act on behalf of the Manufacturer.
- E. HOW THE ORIGINAL OWNER CAN MAKE A WARRANTY CLAIM.**
- 1. The Owner should submit the warranty claim direct to the Manufacturer's Service Department, at the address or phone number listed below, and the Manufacturer will arrange for the handling of the claim.
  - 2. Whenever any inquiry or request is made, be sure to include the water heater's Catalogue Number, Model Number, Serial Number, date of purchase, date of installation, and location of installation.

This Warranty and the Manufacturer's obligations shall be construed and determined in accordance with the laws of both the Province of Ontario, and of Canada in force therein. This Warranty does not affect specific legal rights of a consumer under applicable law, except to the extent that such rights may be waived or replaced, and the provisions hereof are deemed to be amended to the extent necessary. The unenforceability of any provision, in whole or in part, of this Certificate shall not affect the remaining provisions. Any and all repair and/or replacement of part(s) or Unit are the sole and exclusive remedy available against the Manufacturer.

GSW Water Heaters  
 599 Hill Street West  
 Fergus, ON Canada N1M 2X1  
 Should you have any questions, please  
 Visit us online at [www.gsw-wh.com](http://www.gsw-wh.com), or  
 E-mail us at [techsupport@gsw-wh.com](mailto:techsupport@gsw-wh.com), or  
 Call our Technical Support line at 1 888 GSW TECH (479 8324)