



Direct Vent Gas Water Heaters

DESIGNED FOR PERFORMANCE

- Thermopile design provides robust pilot to withstand down drafts and environmental conditions
- LED indicator:
 - Gives visual confirmation that pilot is on by flashing continuously
 - Provides diagnostics and troubleshooting
- Easy temperature adjustments
- Direct vent design means no external power supply or chimney required for operation/installation
- 90" Coaxial vent supplied with water heater
- Top mounted heavy duty anode rod for added tank protection
- Glass-lined tank for longer life
- Factory-installed plastic-lined nipples with heat traps
- CFC-free foam insulation
- Suitable for closet installations due to direct vent design not requiring an external power supply
- 3/4" side taps available on 50 gallon high input model for combination applications

KEEPING YOU SAFE

- Sealed combustion chamber design, eliminating the need for Flammable Vapour sensor

EASY TO INSTALL AND REPAIR

- Combustion chamber is easy to access
- Conveniently located T&P and drain valve for ease of installation and maintenance

LIMITED TANK AND PARTS WARRANTY

- Consult written warranty on the back of this sheet, with documentation included with water heater or contact GSW for complete warranty information.

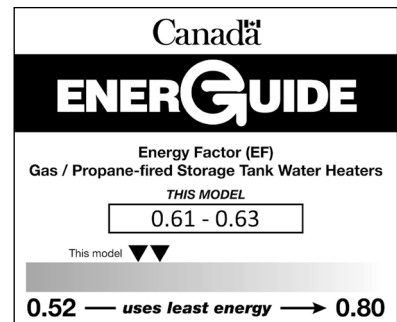



Direct Vent Gas Water Heaters

PERFORMANCE

Tank Warranty**	Model	Series	Capacity	Input	Maximum Certified Altitude	Recovery Rate at 90° F Temperature Rise	First Hour Rating	Energy Factor	BC Compliant
			USG (L)	BTU/h	FT (M)	GPH (LPH)	GPH (LPH)		
6	G640S38NDV	300/301	40 (151)	38,000	7,700 (2,347)	42 (159)	72 (273)	0.63	✓
6	G650T40NDV	300/301	50 (189)	40,000	7,700 (2,347)	43 (163)	91 (344)	0.62	✓
6	G650T47NDV*	300/301	50 (189)	47,000	7,700 (2,347)	51 (193)	92 (348)	0.61	✓

For Propane models sub N with P. Natural gas models are series 300. Propane models are series 301.

*Model has side connections.

**In Residential applications. Reduced warranty in Commercial applications. Parts warranted for 1 year.

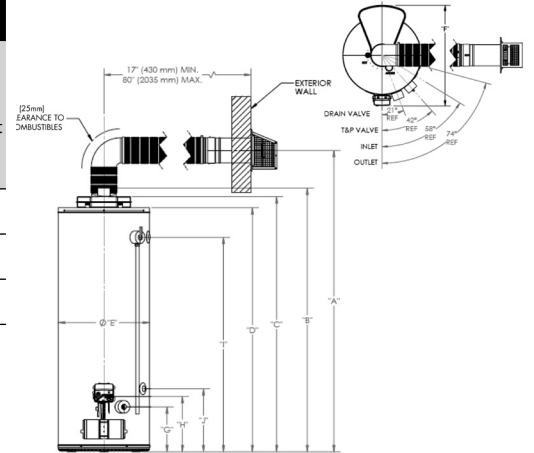

DIMENSIONS & SHIPPING WEIGHT

Model	Height to Center of Vent	Height to Top of Flue Outlet	Height to Top of Air Box	Height to Top of Heater	Diameter	Overall Depth	Height to Drain	Height to Gas Inlet	Height to T&P	Height to Side Tap (Hot Out)	Height to Side Tap (Cold In)	Shipping Weight
	A IN (CM)	B IN (CM)	C IN (CM)	D IN (CM)	E IN (CM)	F IN (CM)	G IN (CM)	H IN (CM)	I IN (CM)	I IN (CM)	J IN (CM)	LB (KG)
G640S38NDV	64 (163)	54 3/8 (138)	52 1/2 (133)	49 5/8 (126)	22 (56)	29 (74)	10 3/4 (27)	13 1/4 (34)	42 3/8 (108)	N/A	N/A	178 (81)
G650T40NDV	73 (185)	63 5/8 (162)	61 3/4 (157)	58 7/8 (150)	22 (56)	29 (74)	10 3/4 (27)	13 1/4 (34)	51 5/8 (131)	N/A	N/A	200 (91)
G650T47NDV*	74 (188)	64 3/8 (164)	62 7/8 (160)	60 (152)	22 (56)	29 (74)	10 3/4 (27)	13 1/4 (34)	52 3/4 (134)	52 3/4 (134)	15 1/4 (39)	215 (98)

PREFERRED INSTALLATION

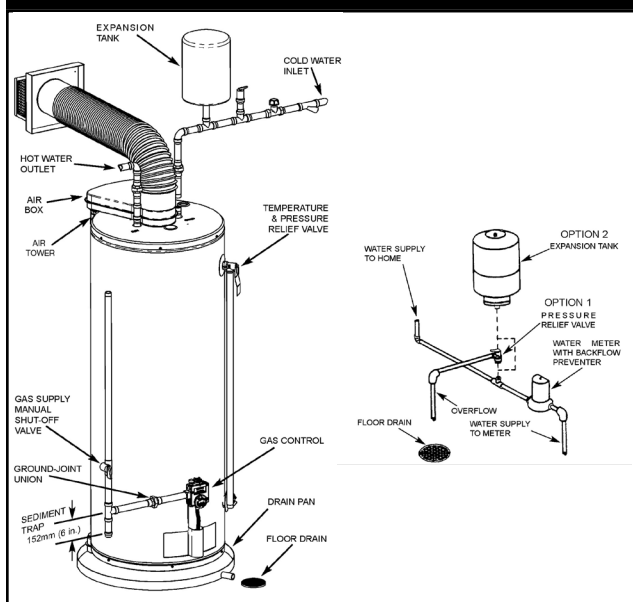

VENT LENGTHS

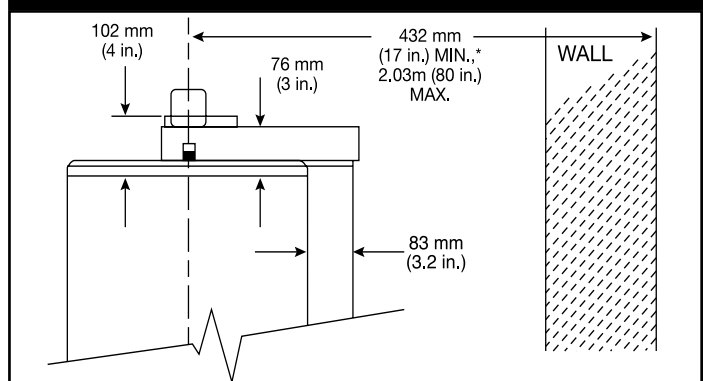

* If the horizontal distance is less than 760mm (30 in.), the restrictor plate must be installed (refer to installation manual for further details).

Refer to the installation manual for complete installation and venting requirements.